

## PASLODE CORDLESS FRAMING NAILER

### TOOL SCHEMATIC AND PARTS

#### **IMPORTANT! DO NOT DESTROY**

Always refer to operating manual #403608 for detailed information on this tool. It is the customer's responsibility to have all operators and service personnel read and understand this information.

# PARTS LEGEND Paslode CORDLESS FRAMING NAILER, 900420

1	900320	1	Grill	51	404827	2	Pin
*2	900315	1	Filter	*52	404419	1	Bumper
3	900469	1	Fan Motor Assembly (Includes PC board, washer and flat retaining ring)	53	404411	3	Spring
4	900300	1	Retaining Ring (flat)	54	900934	2	Steel Ring, Sleeve
→ 5	006562	3	REMOVED	55	901204	1	Sleeve Assembly
6	900470	1	Motor Mount	56	404464	2	Rubber Stop
7	401355	1	Retaining Ring (curved)	57	404424	1	Reed Valve
→ 8	901063	4	Shoulder Screw 10-24 x 1-1/2	58	404422	1	Muffler
→ 9	008388	4	REMOVED	59	404423	1	Muffler Cover
*10	401356	1	Motor Sleeve	→ 60	404468	4	REMOVED
11	900286	1	Spark Plug Assembly, includes O-Ring	→ 61	900596	6	Screw Thread Forming Sems 8-32 x 7/16
12	404428	2	Push Rod	62	403816	2	Socket Head Capscrew 10-24 x 1-1/8
13	404453	1	Bracket, Cylinder Head	63	404445	2	Bushing, Shear Lock
14	404432	1	Bushing, Actuator	64	900975	1	Wear Plate, Nose
15	404444	1	Actuator	65	404410	1	Upper Probe
16	404433	1	Actuator Pin	66	900982	1	Lower Probe
17	401340	1	Stem Adapter	→ 67	900592	2	S.H.C.S. Sems 10-32 x 1/2
18	900471	1	Cylinder Head Machined	68	401380	1	Tie Bar
*19	403992	1	O-Ring	→ 69	900425	1	REMOVED
20	403167	1	Fan Blade Assembly	70	404704	1	Housing Assembly
21	900474	1	Spark Unit Assembly	71	900289	1	Belt Hook
22	900475	1	Molded Circuit Assembly	72	404390	2	Label
23	900478	1	Spark Plug Contact Assembly	73	900980	1	Retainer Ring, Sleeve
24	900231	1	Clip, ESU Wire	→▲ 74	900593	3	S.H.C.S. Sems 10-24 x 5/8
■ 25	403987	2	Screw Thread Forming 6-32 x 1/4	75	403985	1	Follower
26	900461	1	Handle Assembly Kit - Right & Left	76	900520	1	Follower Bushing Spring Assembly
27	404448	1	Roller Lever Assembly	77	901202	1	Retaining Ring
→ 28	404447	1	REMOVED	78	403986	1	Spring Pin
29	404702	2	Screw Thread Forming 6 x 3/8	79	403984	1	Follower Guide
30	404436	1	Nail Channel	80	900297	1	Follower Button
31	404441	1	Cover Plate Magazine	81	404457	1	Spring
→ 32	901222	2	Shoulder Screw 10-32 x 1/2	82	404922	2	Pad, Battery Contact
33	900465	1	Cap	83	401450	5	Fuel Cell Pad
34	404412	1	Wear Plate, Chamber Lock	→■ 84	405141	2	REMOVED
35	900453	4	Screw Plastite 8-16 x 7/8	85	900983	1	Cage Stop
** 36	900508	1	Warning Label	86	404426	1	Exhaust Baffle
37	404442	1	Channel Magazine	87	404425	1	Reed Plate
→■ 38	900594	4	S.H.C.S. Sems 8 - 32 x 1/2	■ 88	900969	4	Torx Screw 8-32 x 5/8
→ 39	404414	4	REMOVED	89	900481	1	O-Ring
40	404451	1	Lockout Bar, Follower	**90	900497	1	Warning Label
→ 41	901203	1	Shear Block	91	900372	1	Combustion Chamber Ring
44	404435	1	Trigger	92	404407	1	Combustion Chamber
45	900269	1	Chamber Lock Bar	→ 93	900595	2	Torx Screw Sems 8-32 x 3/8
46	404927	1	Spring, Trigger	→ 94	004238	5	REMOVED
47	401328	1	Retainer ring	→ 95	901260	1	Nameplate
48	401461	2	Piston Ring	96	900427	1	Light Pipe
49	404485	1	Piston Assembly	97	900468	1	Washer, Motor Shaft
50	900521	1	Combustion Chamber Assembly	→ 98	900349	4	REMOVED
				→ 99	900546	1	Brass Insert
				→ 100	900597	4	Screw Thread Forming Sems 6-19 x 3/8

- \* Denotes normal wear items
- \*\* Make sure Warning Labels (#900497,900508) are properly affixed. Replace if necessary. Label is available at no charge through the Service Department.
- ▲ Apply Loctite 242 (Blue) Part No. 093500.
- Apply Loctite RC-620 (Green) Part No. 401491
- Denotes new change.

## SAFETY INSTRUCTIONS

### WEAR EYE AND HEARING PROTECTION



Always wear hearing protection and eye protection devices, including side shields when operating or working in the vicinity of a tool.

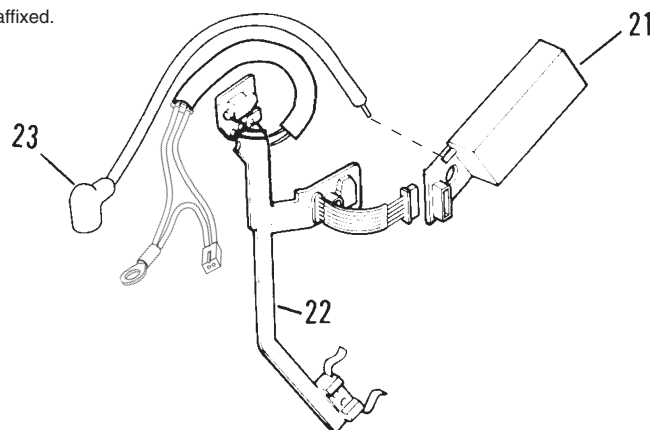
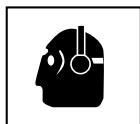

### ⚠ WARNING

All parts must be periodically inspected and replaced if worn or broken. Failure to do this can affect the tool's operation and present a safety hazard.

# CORDLESS FRAMING NAILER, 900420

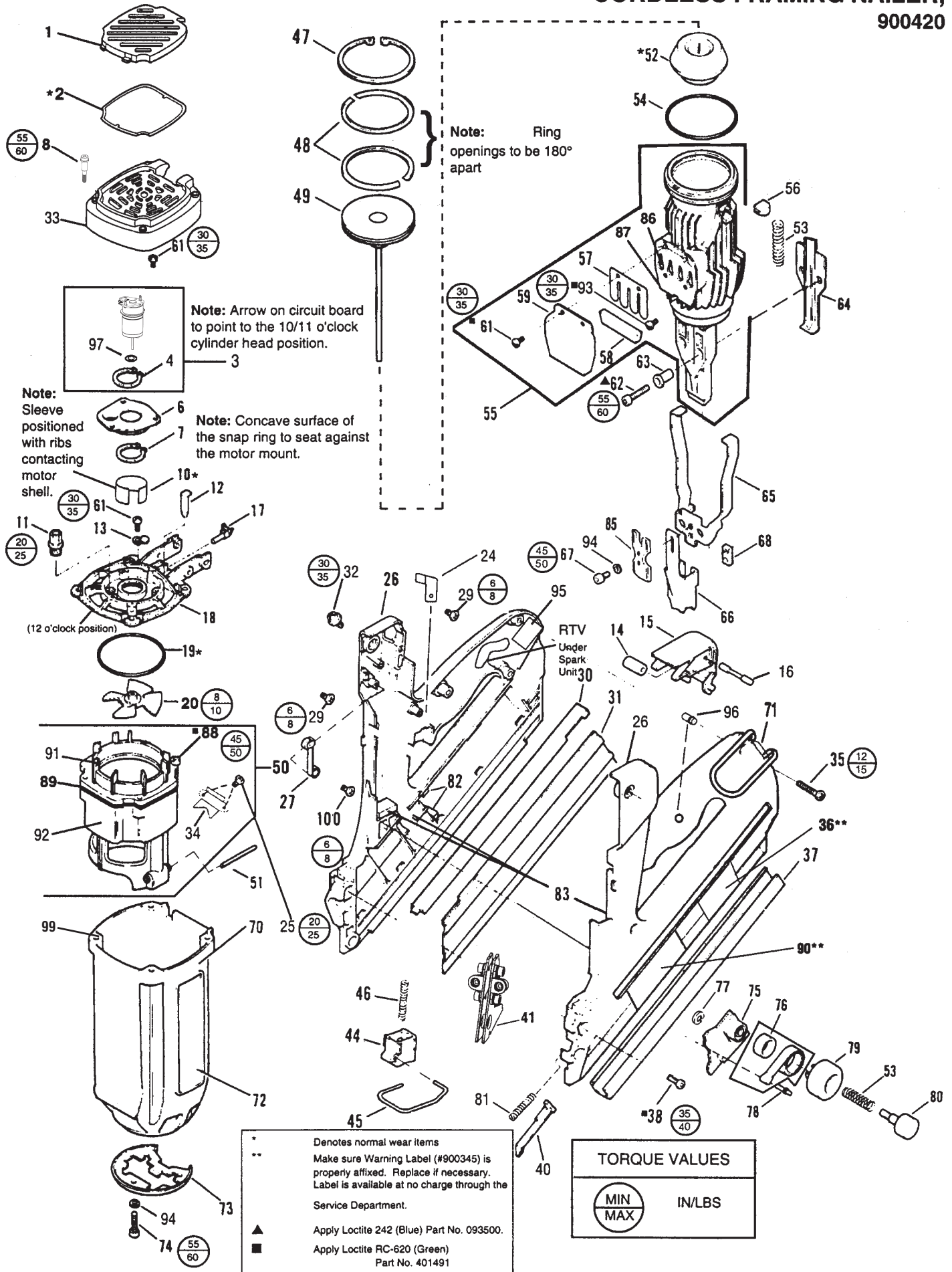

# ACCESSORIES

---

## Car Adapter

Enables you to re-charge your battery with your vehicle's electrical system.

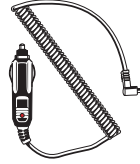

Part No. 900507

---

## Battery Cell



Part No. 404717

---

## Impulse Oil



Part No. 401482

---

## 5/32" Hex Key

For adjusting work contacting element.



Part No. 401331

---

## No-Mar Work Contacting Element

Rubber tipped WCE to eliminate marring work surface.  
(Replacement rubber tip, Part No. 403369)

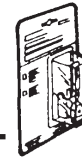

Part No. 404705

---

## Paslode Cordless Nailer Case

Part No. 404710

---

## Clear Safety Glasses



Part No. 402510

---

## Tinted Safety Glasses



Part No. 402512

---

## Degreaser Cleaner

Ideal cleaner for all Paslode® tools.

Part No. 219086

---

## Battery Charger Kit

(Replacement Charger Base Only Part No. 900476)  
(Replacement Transformer Only Part No. 900477- US/CANADA)

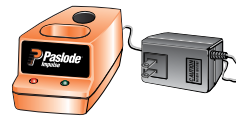

Part No. 900200

(Replacement Transformer Only Part No. 900505 Continental Europe)  
(Replacement Transformer Only Part No. 900506 U.K.)  
(Replacement Transformer Only Part No. 900504 Australia)



An Illinois Tool Works Company  
888 Forest Edge Drive  
Vernon Hills, Illinois 60061