

# PARTS MANUAL



## ***WHITEMAN* SERIES** **MODEL CA4HM** **WALK-BEHIND TROWEL** **(HONDA GASOLINE ENGINE)**

MODEL # \_\_\_\_\_

SERIAL # \_\_\_\_\_

Revision #2 (08/07/06)



# **WARNING**



## **CALIFORNIA — Proposition 65 Warning**

Engine exhaust and some of its constituents, and some dust created by power sanding, sawing, grinding, drilling and other construction activities contains chemicals known to the State of California to cause cancer, birth defects and other reproductive harm. Some examples of these chemicals are:

- Lead from lead-based paints.
- Crystalline silica from bricks.
- Cement and other masonry products.
- Arsenic and chromium from chemically treated lumber.

Your risk from these exposures varies, depending on how often you do this type of work. To reduce your exposure to these chemicals: **ALWAYS** work in a well ventilated area, and work with approved safety equipment, such as dust masks that are specially designed to filter out microscopic particles.

## **HERE'S HOW TO GET HELP**

PLEASE HAVE THE MODEL AND SERIAL  
NUMBER *ON-HAND* WHEN CALLING

### ***MULTIQUIP'S MAIN PHONE NUMBERS***

800-421-1244      FAX: 310-537-3927  
310-537-3700

### ***PARTS DEPARTMENT***

800-427-1244      FAX: 800-672-7877  
310-537-3700      FAX: 310-637-3284

### ***MAYCO PARTS***

800-306-2926      FAX: 800-672-7877  
310-537-3700      FAX: 310-637-3284

### ***SERVICE DEPARTMENT***

800-478-1244      FAX: 310-537-4259  
310-537-3700

### ***MQ POWER SERVICE DEPARTMENT***

800-835-2551      FAX: 310-638-8046  
310-537-3700

### ***TECHNICAL ASSISTANCE***

800-478-1244      FAX: 310-631-5032

### ***WARRANTY DEPARTMENT***

800-421-1244, EXT. 279      FAX: 310-537-1173  
310-537-3700, EXT. 279

Your Local Dealer is:



# CA4HM TROWEL—TABLE OF CONTENTS

## MQ WHITEMAN CA4HM WALK-BEHIND TROWEL

Here's How To Get Help .....	3
Table Of Contents .....	4
Parts Ordering Procedures .....	5
Explanation of Codes in Remarks Column .....	6
Suggested Spare Parts .....	7

## Component Drawings

Nameplate and Decals .....	8-9
Quick Pitch Handle Assy. ....	10-11
Spider Assy. ....	12-13
Gearbox Assy. ....	14-15
Engine 4HP Honda Assy. (up to sn CL0132684).....	16-17
Engine 4HP Honda Assy. (after sn CL0132684).....	18-19
Guard Ring .....	20-21
Blades and Pans Assy. ....	22-23

## Honda GX120K1 QX2 Engine

Air Cleaner (Dual) Assy. ....	24-25
Camshaft Assy. ....	26-27
Carburetor Assy. ....	28-29
Control Assy. ....	30-31
Crankcase Cover Assy. ....	32-33
Crankshaft Assy. ....	34-35
Cylinder Barrel Assy. ....	36-37
Cylinder Head Assy. ....	38-39
Fan Cover Assy. ....	40-41
Flywheel Assy. ....	42-43
Fuel Tank Assy. ....	44-45
Ignition Coil Assy. ....	46-47
Muffler Assy. ....	48-49
Piston Assy. ....	50-51
Recoil Starter Assy. ....	52-53
Gasket Kit Assy. ....	54-55
Labels .....	56-57

Terms and Condition Of Sale — Parts .....	58
---	----

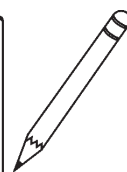
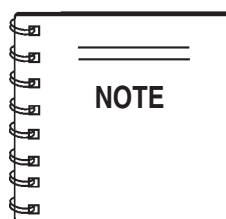

**Specifications and part numbers are subject to change without notice.**

www.multiquip.com

**Ordering parts has never been easier!  
Choose from three easy options:**



**Order via Internet (Dealers Only):**

Order parts on-line using Multiquip's SmartEquip website!

- View Parts Diagrams
- Order Parts
- Print Specification Information



If you have an MQ Account, to obtain a Username and Password, E-mail us at: [parts@multiquip.com](mailto:parts@multiquip.com).

To obtain an MQ Account, contact your District Sales Manager for more information.

Goto [www.multiquip.com](http://www.multiquip.com) and click on **Order Parts** to log in and save!

Use the **internet** and qualify for a **5% Discount** on *Standard orders* for all orders which include complete part numbers.\*

Note: Discounts Are Subject To Change



**Order via Fax (Dealers Only):**

All customers are welcome to order parts via Fax.

**Domestic (US) Customers dial:**  
1-800-6-PARTS-7 (800-672-7877)

**Fax** your order in and qualify for a **3% Discount** on *Standard orders* for all orders which include complete part numbers.\*

Note: Discounts Are Subject To Change



**Order via Phone: Domestic (US) Dealers Call:**  
1-800-427-1244

**Non-Dealer Customers:**

Contact your local Multiquip Dealer for parts or call 800-427-1244 for help in locating a dealer near you.



**International Customers** should contact their local Multiquip Representatives for Parts Ordering information.

**When ordering parts, please supply:**

- |  |  |
|--|--|
| <ul style="list-style-type: none"> <li><input type="checkbox"/> Dealer Account Number</li> <li><input type="checkbox"/> Dealer Name and Address</li> <li><input type="checkbox"/> Shipping Address (if different than billing address)</li> <li><input type="checkbox"/> Return Fax Number</li> <li><input type="checkbox"/> Applicable Model Number</li> <li><input type="checkbox"/> Quantity, Part Number and Description of Each Part</li> </ul> | <ul style="list-style-type: none"> <li><input type="checkbox"/> Specify Preferred Method of Shipment:                     <ul style="list-style-type: none"> <li><input checked="" type="checkbox"/> Fed Ex/UPS      <input checked="" type="checkbox"/> DHL</li> <li><input type="checkbox"/> Priority One      <input checked="" type="checkbox"/> Truck</li> <li><input type="checkbox"/> Ground</li> <li><input type="checkbox"/> Next Day</li> <li><input type="checkbox"/> Second/Third Day</li> </ul> </li> </ul> |
|--|--|

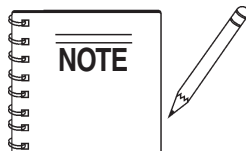

Unless otherwise indicated by customer, all orders are treated as *Standard Orders* and will ship within 24 hours. We will make every effort to ship *Air Shipments* the same day the order is received, if received prior to 2PM PST. *Stock Orders* must be noted on fax or web order form.

**WE ACCEPT ALL MAJOR CREDIT CARDS!**



# CA4HM TROWEL — EXPLANATION OF CODES IN REMARKS COLUMN

How to read the marks and remarks used in this parts book.

## Section 1: Items Found In the “Remarks” Column

**Serial Numbers**-Where indicated, this indicates a serial number range (inclusive) where a particular part is used.

**Model Number**-Where indicated, this shows that the corresponding part is utilized only with this specific model number or model number variant.

## Items Found In the “Items Number” Column

All parts with same symbol in the number column, \*, #, +, %, or >, belong to the same assembly or kit.

**Note:** If more than one of the same reference number is listed, the last one listed indicates newest (or latest) part available.

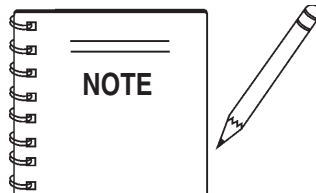

The contents of this parts catalog are subject to change without notice.

## CA4HM TROWEL — SUGGESTED SPARE PARTS

### CA4HM TROWEL 1 TO 3 UNITS WITH HONDA GX120K1QX2 GASOLINE ENGINE.

#### *1 to 3 Units*

Qty.....	P/N .....	Description
3 .....	0189 .....	GRIP
1 .....	21046 .....	GASKET KIT
1 .....	21047 .....	BEARING KIT
2 .....	9807354776 .....	SPARK PLUG HONDA
2 .....	17631ZH7003 .....	TANK CAP (HONDA)
3 .....	17211896000 .....	AIR CLEANER ELEMENT (HONDA)
2 .....	17218ZE2505 .....	FILTER OUTER (HONDA)
1 .....	1714 .....	PITCH CABLE
1 .....	10607 .....	THRUST BEARING
1 .....	10567 .....	THRUST COLLAR
1 .....	10639 .....	WEAR PLATE
3 .....	2343 .....	V-BELT (A-25)
1 .....	0302 .....	CABLE, THROTTLE
2 .....	10139 .....	GEARBOX LUBRICANT
1 .....	10936 .....	CABLE ASSY. HAND CLUTCH

# CA4HM TROWEL — NAMEPLATE AND DECALS

## NAMEPLATE AND DECALS

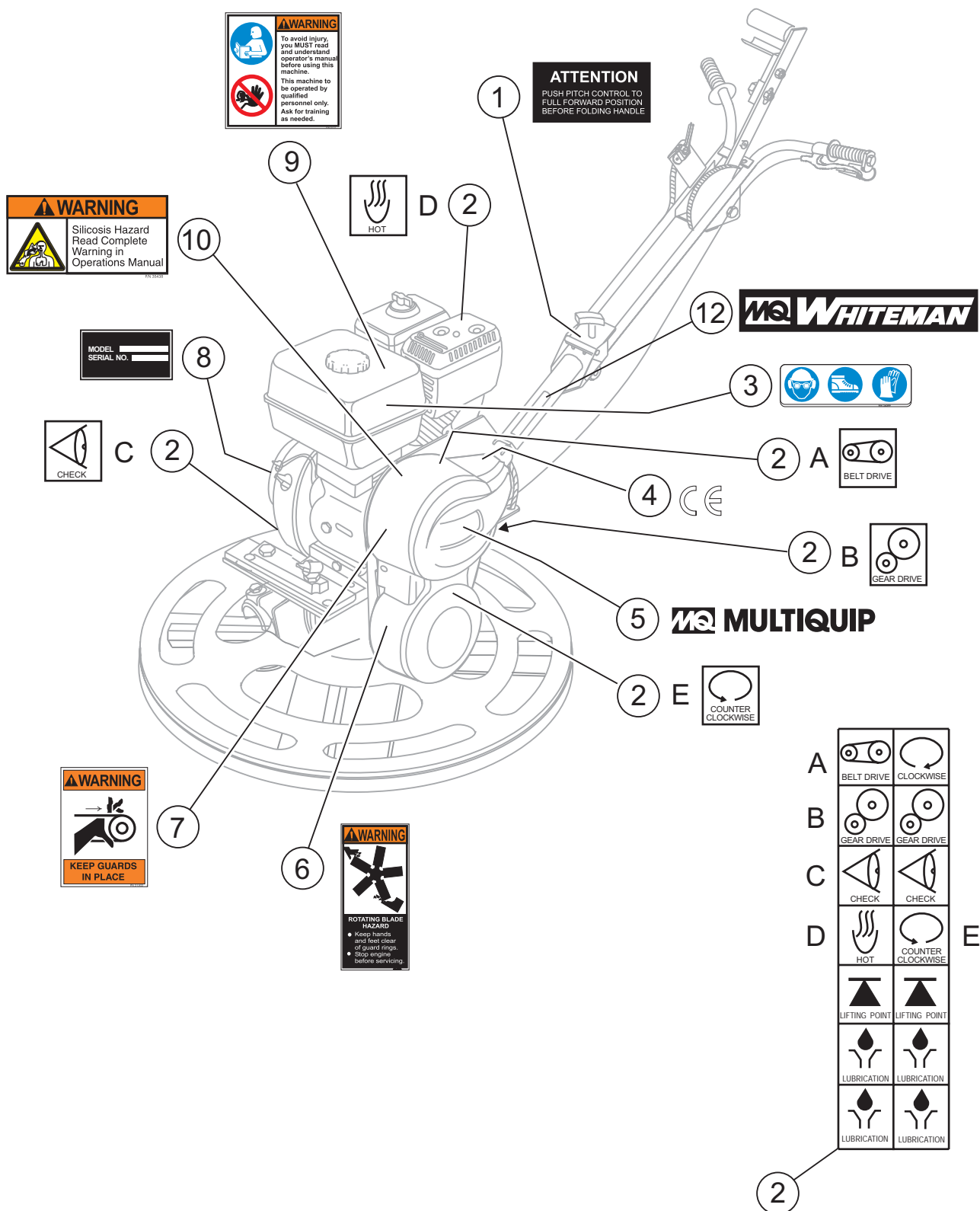



# CA4HM TROWEL — NAMEPLATE AND DECALS

## NAMEPLATE AND DECALS

<u>NO.</u>	<u>PART NO.</u>	<u>PART NAME</u>	<u>QTY.</u>	<u>REMARKS</u>
1	10732	DECAL: CAUTION PITCH HANDLE .....	1 .....	SAFETY ITEM
2A	11246	DECAL: BELT DRIVE .....	1 .....	SAFETY ITEM
2B	11246	DECAL: GEAR DRIVE .....	1 .....	SAFETY ITEM
2C	11246	DECAL: CHECK OIL	1	
2D	11246	DECAL: HEAT	1	SAFETY ITEM
2E	11246	DECAL: COUNTER CLOCKWISE.....	1 .....	SAFETY ITEM
3	36099	DECAL: HELMET, SHOE AND GLOVE .....	1 .....	SAFETY ITEM
4	11092	DECAL: CE	1	
5	20816	DECAL: MQ MULTIQUIP	1	
6	35168	DECAL: WARNING, BLADE RISK .....	1 .....	SAFETY ITEM
7	21302	DECAL: WARNING, GUARDS .....	1 .....	SAFETY ITEM
8		NAME PLATE .....	1 .....	CONTACT MULTIQUIP ..... PARTS DEPARTMENT
9	35137	DECAL: WARNING, READ MANUAL .....	1 .....	SAFETY ITEM
10	35438	DECAL: WARNING, SILICOSIS HAZARD .....	1 .....	SAFETY ITEM

# CA4HMTROWEL — QUICK PITCH™ HANDLE ASSY.

QUICK PITCH™ HANDLE ASSY.

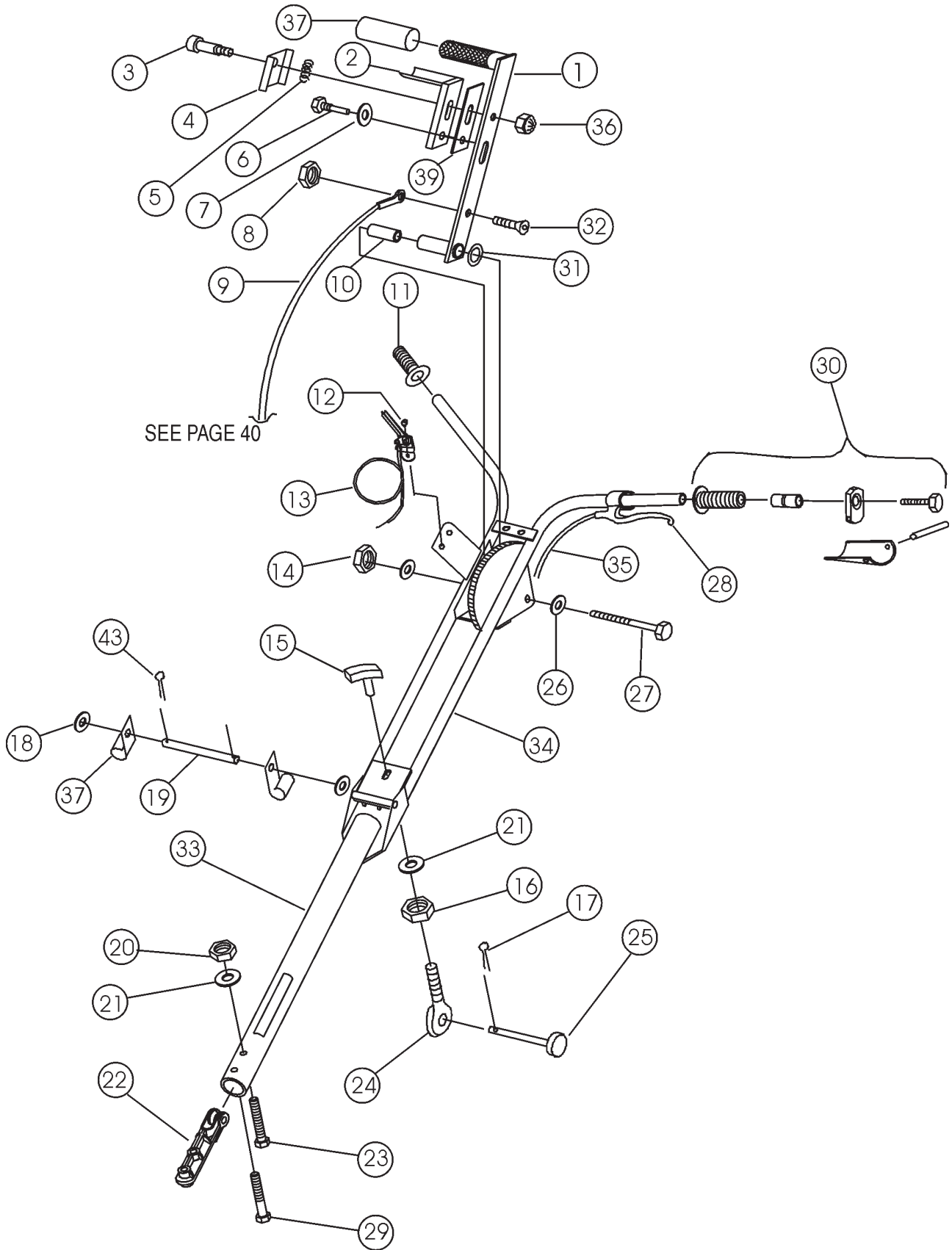

# CA4HM TROWEL — QUICK PITCH™ HANDLE ASSY.

## QUICK PITCH™ HANDLE ASSY.

<u>NO.</u>	<u>PART NO.</u>	<u>PART NAME</u>	<u>QTY.</u>	<u>REMARKS</u>
1	10657	PITCH CONTROL HANDLE	1	
2	10881	LATCHING BAR	1	
3	3910382	SHOULDER BOLT 3/8 X 3/8	1	
4	10655	LATCH RETURN SPRING COVER	1	
5	10654	LATCH RETURN SPRING	1	
6	10659	QP LATCHING BOLT	1	
6	10878	QP LATCHING BOLT	1	
7	0161 C	LOCK WASHER 5/16"	1	
8	10024	LOCK NUT 1/4- 20	1	
9	1714	CABLE, PITCH CONTROL	1	
10	10658	CONTROL HANDLE SUPPORT TUBE	1	
11	0189	HANDLE GRIP	1	
12	0304	SCREW, RHM 10- 24 X 1/4"	2	
13	0302	THROTTLE ASSEMBLY CABLE	1	
14	5283	LOCK NUT 5/16- 18	1	
15	10651	STAR WHEEL	1	
16	1456	NUT, HEX FINISH 3/8- 16	1	
17	3216	COTTER PIN	3	
18	0948	FLAT WASHER 1/4"	2	
19	10629	HANDLE HINGE PIN	1	
20	10133	LOCK NUT 3/8- 16	2	
21	10136	FLAT WASHER 3/8"	3	
22	20280	SUPPORT BLOCK	1	
23	21017	SCREW, HHC 3/8- 16 X 3.25 FULL THRD	1	
24	10701	SWING BOLT	1	
25	5291	CLEVIS PIN	1	
26	0300 B	FLAT WASHER 5/16"	2	
27	0669 A	SCREW, HHC 5/16- 18 X 2-1/4"	1	
28	1512	CLUTCH HAND LEVER	1	
29	1493	SCREW, HHC 3/8 - 16 X 3.25	1	
30	10036	CLUTCH ASSIST HANDLE ASSY.	1	
31	10660	SHIM	1	
32	3164	SCREW, FHSC 1/4- 20 X 1"	1	
33	21438	LOWER HANDLE	1	
34	10635	UPPER HANDLE	1	
35	10653	CLUTCH CABLE ASSY.	1	
36	10676	ACORN NUT 5/16- 18	1	
37	8128	CLAMP	2	
39	11015	HANDLE SLIDER	1	

# CA4HMTROWEL — SPIDER ASSY.

## SPIDER ASSY.

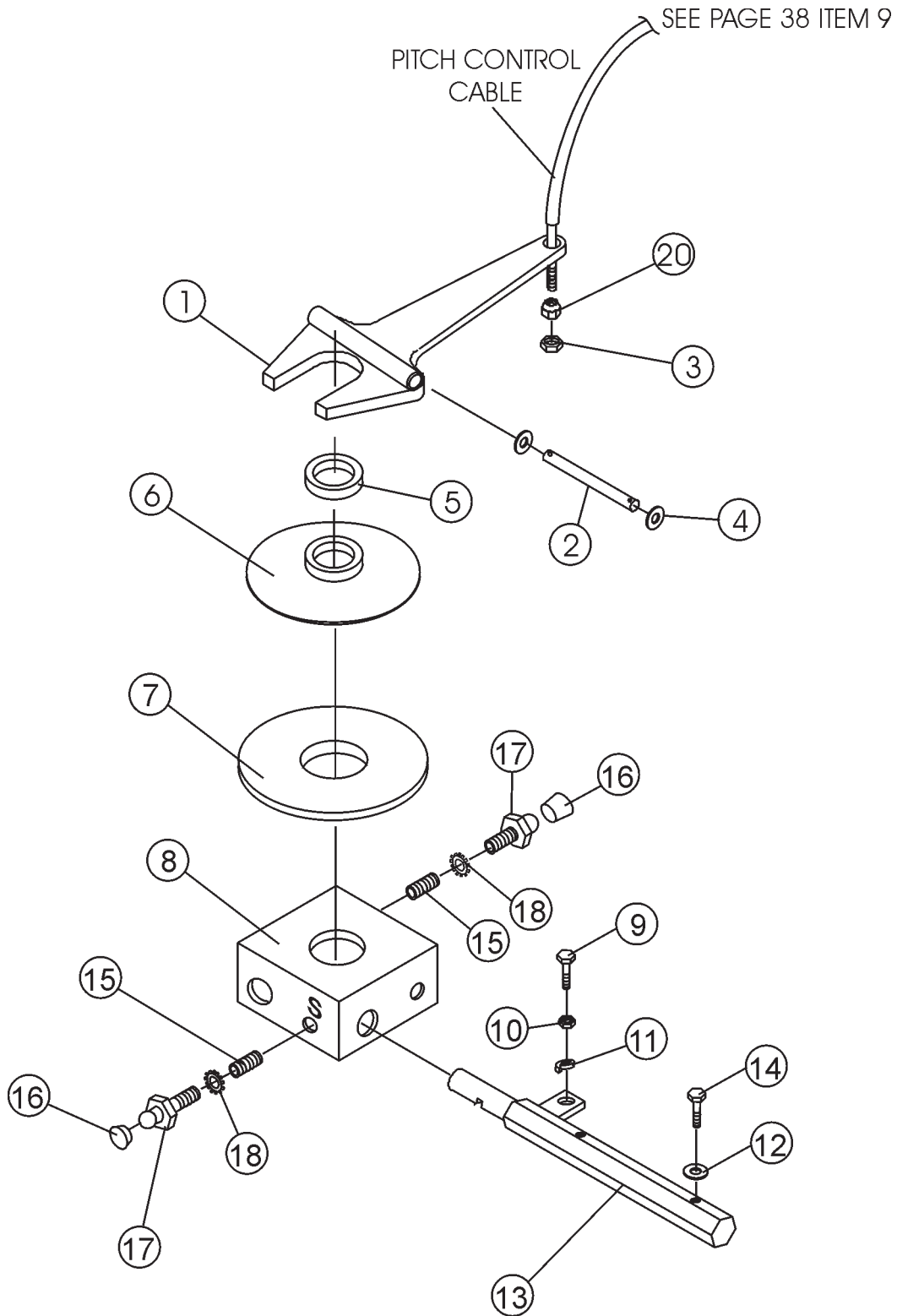

# CA4HM TROWEL — SPIDER ASSY.

## SPIDER ASSY.

<u>NO.</u>	<u>PART NO.</u>	<u>PART NAME</u>	<u>QTY.</u>	<u>REMARKS</u>
1	21477	YOKE	1	
2	20801	YOKE PIN	1	
3	1116	NUT, BRASS JAM 5/16- 18	1	
4	20802	SNAP RING	2	
5	10607	THRUST BEARING	1	
6	10567	THRUST COLLAR	1	
7	10639	WEAR PLATE	1	
8	10563	SPIDER	1	
9	0164 B	SCREW, HHC 3/8- 16 X 1-1/4 F.T.	4	
10	1876	NUT, JAM 3/8- 16	4	
11	0166 A	LOCK WASHER 3/8"	4	
12	0181 B	LOCK WASHER 1/4"	8	
13	10768	TROWEL ARM	4	
14	10790	SCREW, HHC M6- 1 X 30MM	8	
15	0685	SCREW, SHS 5/16- 18 X 5/16"	2	
16	1162 A	GREASE ZERK CAP	4	
17	10587	ARM RETAINING SCREW	4	
18	1875	WASHER, INT. SHKP. 3/8"	4	
20	10698	NUT, ADJUSTING 5/16- 18	1	

# CA4HMTROWEL — GEARBOX ASSY.

## GEARBOX ASSY.

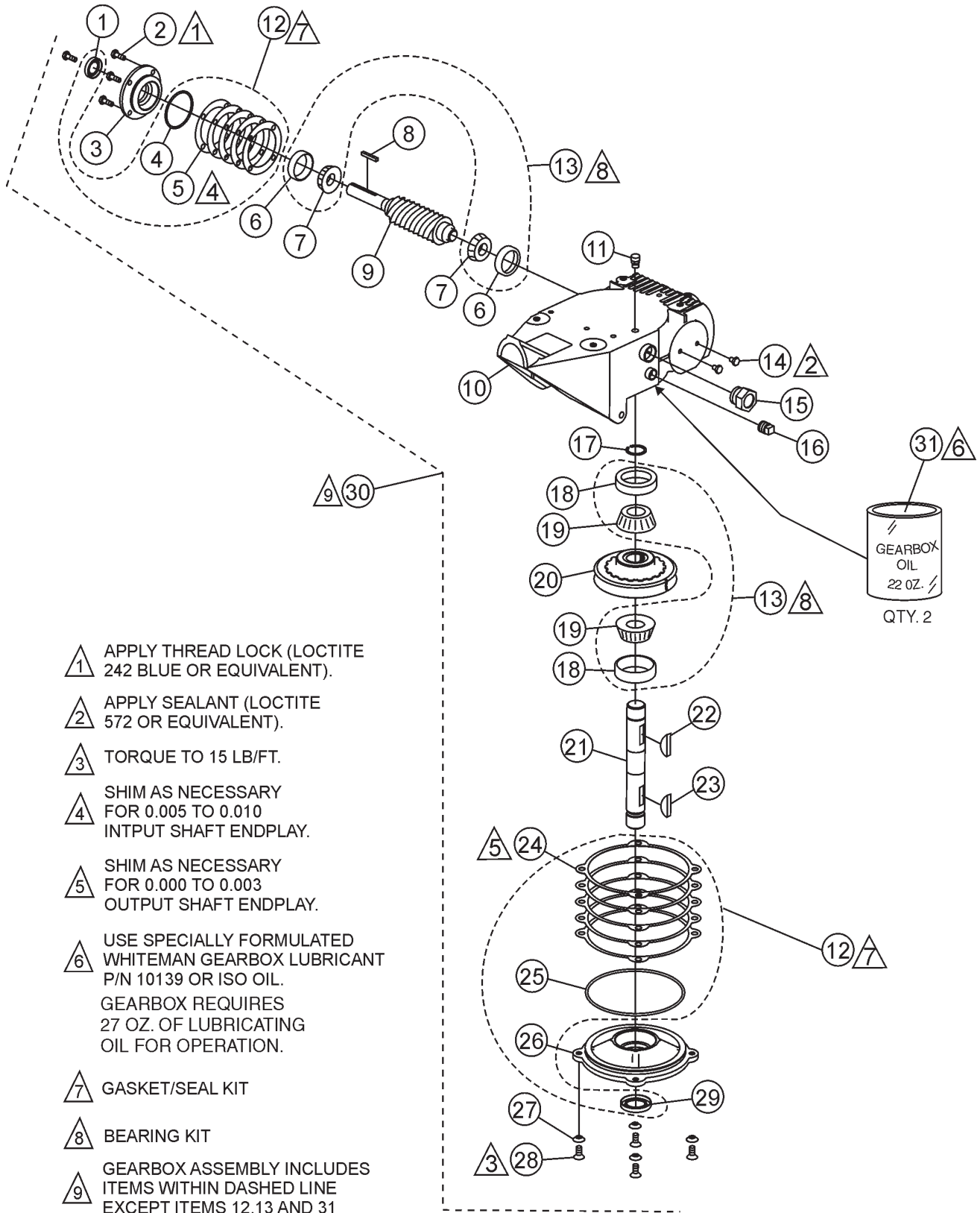

- ▲ 1 APPLY THREAD LOCK (LOCTITE 242 BLUE OR EQUIVALENT).
- ▲ 2 APPLY SEALANT (LOCTITE 572 OR EQUIVALENT).
- ▲ 3 TORQUE TO 15 LB/FT.
- ▲ 4 SHIM AS NECESSARY FOR 0.005 TO 0.010 INPUT SHAFT ENDPLAY.
- ▲ 5 SHIM AS NECESSARY FOR 0.000 TO 0.003 OUTPUT SHAFT ENDPLAY.
- ▲ 6 USE SPECIALLY FORMULATED WHITEMAN GEARBOX LUBRICANT P/N 10139 OR ISO OIL. GEARBOX REQUIRES 27 OZ. OF LUBRICATING OIL FOR OPERATION.
- ▲ 7 GASKET/SEAL KIT
- ▲ 8 BEARING KIT
- ▲ 9 GEARBOX ASSEMBLY INCLUDES ITEMS WITHIN DASHED LINE EXCEPT ITEMS 12,13 AND 31

# CA4HMTROWEL — GEARBOX ASSY.

## GEARBOX ASSY.

<u>NO.</u>	<u>PART NO.</u>	<u>PART NAME</u>	<u>QTY.</u>	<u>REMARKS</u>
1%*	0753	SEAL, OIL NATIONAL	1	
2%	0131 A	SCREW, HHC 1/4-20 X 3/4	4	
3%	12876	FLANGE, INPUT SHAFT	1	
4%*	20395	RING, O -139 BUNA N	1	
5%*	20397	SHIM, INPUT 0.002 THICK	1	
5%*	20398	SHIM, INPUT 0.003 THICK	1	
5%*	20399	SHIM, INPUT 0.005 THICK	1	
5%*	20400	SHIM, INPUT 0.010 THICK	1	
5%*	20401	SHIM, INPUT 0.020 THICK	1	
6%#	21218	BEARING, CUP, TIMKEN	2	
7%#	20465	BEARING, CONE, TIMKEN	2	
8%	0627	KEY, SQUARE 3/16 X 1 1/4	1	
9%	1851	GEAR, WORM & SHAFT ASSY.	1	
10%	21454	CASE, GEAR	1	
11%	21218	VENT, AIR	1	
12	21046	GASKET/SEAL KIT .....	1	INCLUDES ITEMS W/*
13	21047	BEARING KIT .....	1	INCLUDES ITEMS W/ #
14%	20476	SCREW, HHC 1/4-28 X 3/8	2	
15%	21033	SIGHT GLASS, 3/4 M PIPE STEEL	1	
16%	0121 A	FITTING, PLUG 3/8 MP SQ HEAD	1	
17%	1138	RING, SNAP, TRUARC 5100-112	1	
18%#	20475	BEARING, CUP TIMKEN	2	
19%#	20474	BEARING, CONE TIMKEN	2	
20%	1140	GEAR, WORM, BRONZE	1	
21%	21435	SHAFT, OUTPUT	1	
22%	1139	KEY, WOODRUFF #21 HARDENED	1	
23%	1238	KEY, WOODRUFF #25	1	
24%*	20402	SHIM, OUTPUT 0.002 THICK	1	
24%*	20403	SHIM, OUTPUT 0.003 THICK	1	
24%*	20404	SHIM, OUTPUT 0.005 THICK	1	
24%*	20405	SHIM, OUTPUT 0.010 THICK	1	
24%*	20406	SHIM, OUTPUT 0.020 THICK	1	
25%*	20396	RING, O -257 BUNA N	1	
26%	12875	COVER, GEARBOX	1	
27%	10235	WASHER, C/S EXT. SHKP	4	
28%	1146	SCREW, FHSC 5/16-18 X 1, NYLOC NP	4	
29%*	0254	SEAL, OIL, NATIONAL	1	
30	21436	GEARBOX ASSY. ....	1	INCLUDES ITEMS W/ %
31	10139	GEARBOX OIL 22 OZ. ....	2	REQUIRES 27 OZ.

# CA4HM TROWEL — ENGINE, 4 HP HONDA ASSY. (UP TO S/N CL0132684)

ENGINE, 4 HP HONDA ASSY. (UP TO S/N CL0132684)

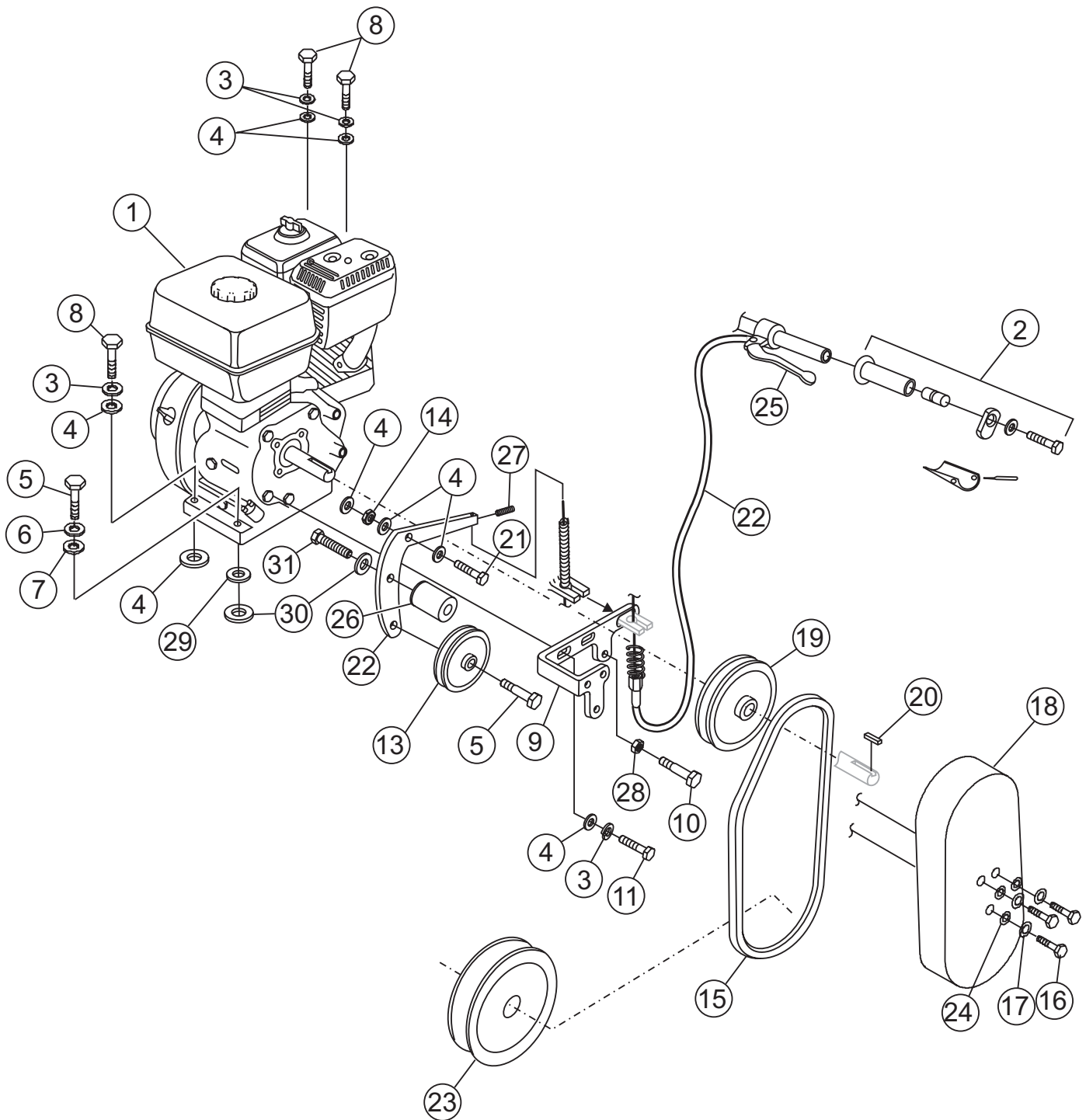



# CA4HMTROWEL — ENGINE, 4 HP HONDA ASSY. (UP TO S/N CL0132684)

ENGINE, 4 HP HONDA ASSY. (UP TO S/N CL0132684)

<u>NO.</u>	<u>PART NO.</u>	<u>PART NAME</u>	<u>QTY.</u>	<u>REMARKS</u>
1	21387	ENGINE, 4 HP. HONDA GX120K1QX2	1	
2	10036	HANDLE ASSY., CLUTCH ASSIST	1	
3	0161 C	LOCK WASHER 5/16"	5	
4	0300 B	FLAT WASHER 5/16"	11	
5	1284	SCREW, HHC 3/8 -16 X 1-1/2"	2	
6	0166 A	LOCK WASHER 3/8"	1	
7	10136	FLAT WASHER 3/8"	1	
8	0105	SCREW, HHC 5/16- 18 X 1-1/2"	2	
9	10644	CLUTCH BRACKET	1	
10	5277	SCREW, HHC 1/4- 20 X 1-1/2"	1	
11	10229	SCREW, HHC 5/16 - 24 X 1"	2	
12	10936	CABLE ASSY., HAND CLUTCH	1	
13	10608	IDLER PULLEY	1	
14	6014 C	NUT, HEX 5/16 X 24	1	
15	10611	BELT (A21)	1	
16	0730	SCREW, HHC 1/4- 20 X 1"	3	
17	0181 B	LOCK WASHER 1/4"	5	
18	10661	BELT GUARD .....	1	SAFETY ITEM
19	21492	PULLEY	1	
20	10909	SQUARE KEY 3/16 X 3/16 X 13/16"	1	
21	10181	SCREW, HHC 5/16 - 24 X 1-1/4"	1	
22	20979	CLUTCH LEVER	1	
23	10610	PULLEY	1	
24	0948	FLAT WASHER 1/4"	5	
25	1512	CONTROL LEVER, HAND CLUTCH	1	
26	20981	SHOE, BELT HAND CLUTCH	1	
27	10450	SHS 10- 32 X 1/4"	1	
28	0949	HEX NUT 1/4- 20	1	
29	1733	WASHER, 1/2 X 1/32	1	
30	13351	WASHER, FLAT USS 3/8 EXT. THK.	1	
31	1672	SCREW, HHC 3/8 -24 X 1"	1	

# CA4HM TROWEL — ENGINE, 4 HP HONDA ASSY. (AFTER S/N CL0132684)

ENGINE, 4 HP HONDA ASSY. (AFTER S/N CL0132684)

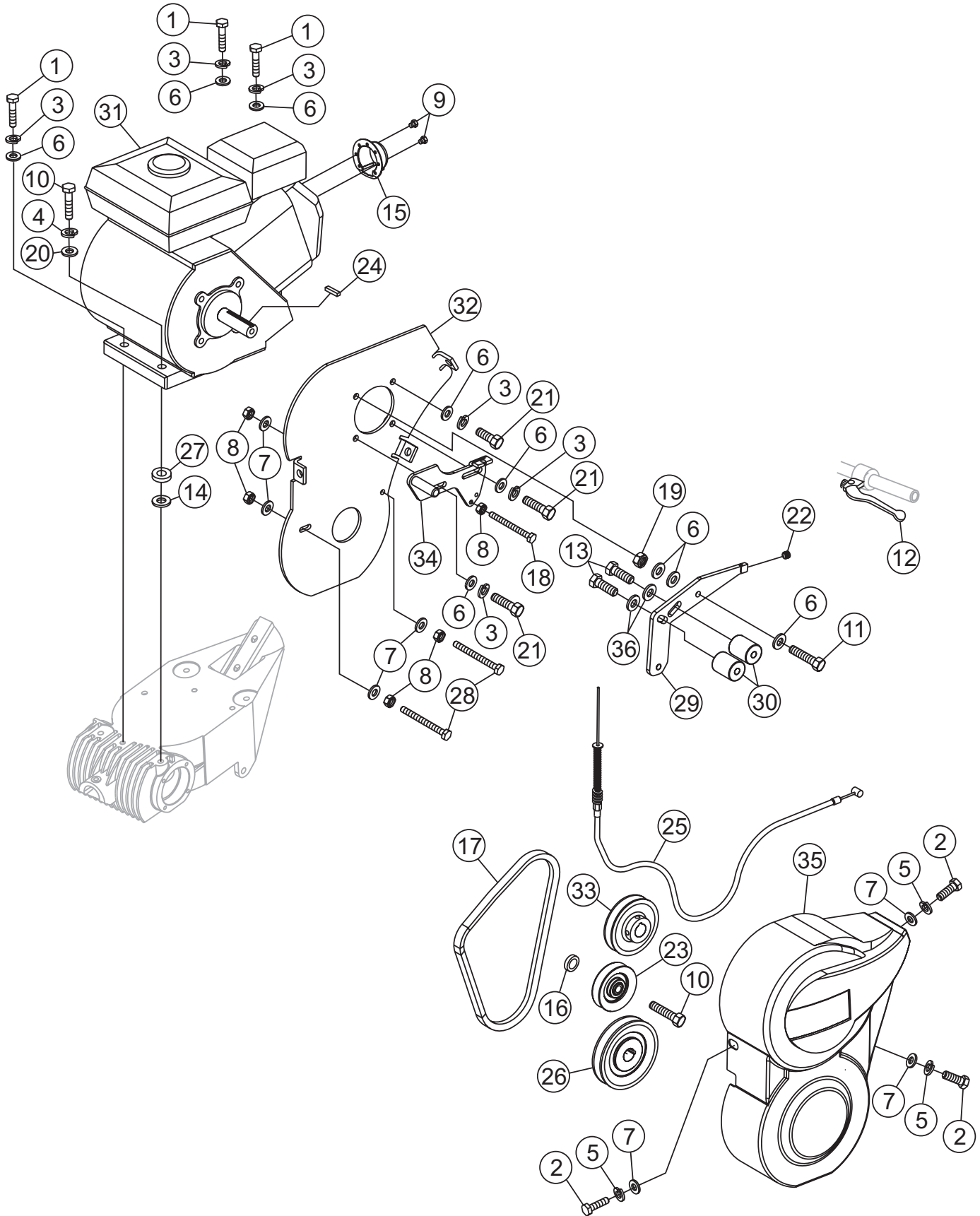

# CA4HM TROWEL — ENGINE, 4 HP HONDA ASSY. (AFTER S/N CL0132684)

ENGINE, 4 HP HONDA ASSY. (AFTER S/N CL0132684)

<u>NO.</u>	<u>PART NO.</u>	<u>PART NAME</u>	<u>QTY.</u>	<u>REMARKS</u>
1	0105	SCREW, HHC 5/16- 18 X 1-1/2	3	
2	0131 A	SCREW, HHC 1/4 - 20 X 3/4	3	
3	0161 C	LOCK WASHER 5/16	6	
4	0166 A	LOCK WASHER 3/8	1	
5	0181 B	LOCK WASHER 1/4	3	
6	0300 B	FLAT WASHER 5/16	9	
7	0948	FLAT WASHER 1/4	7	
8	0949	HEX NUT 1/4- 20	5	
9	1273	SCREW, HHST 3- 32 X 3/8	2	
10	1284	SCREW, HHC 3/8 -16 X 1-1/2	2	
11	1391	SCREW, HHC 5/16 - 24 X 1-1/2 ZINC	1	
12	1512	CONTROL LEVER, HAND CLUTCH	1	
13	1672	SCREW, HHC 3/8 -24 X 1	2	
14	1733	WASHER, 1/2 X 1/32	1	
15	1834	DEFLECTOR, HONDA EXHAUST	1	
16	1897	SPACER	1	
17	2343	BELT (A25)	1	
18	4538	SCREW, HHC 1/4- 20 X 2-1/2	1	
19	6014 C	NUT, HEX 5/16 X 24	1	
20	10136	FLAT WASHER 3/8	1	
21	10181	SCREW, HHC 5/16 - 24 X 1-1/4	3	
22	10450	SHS 10- 32 X 1/4	1	
23	10608	PULLEY, IDLER	1	
24	10909	SQUARE KEY 3/16 X 11/16	1	
25	10936	CABLE ASSY., HAND CLUTCH	1	
26	11043	PULLEY, AK41 X 3/4	1	
27	13351	WASHER, FLAT USS 3/8 EXT. THK.	1	
28	19380	SCREW, HHC 1/4 - 20 X 3	2	
29	20977	CLUTCH LEVER	1	
30	20981	SHOE, BELT HAND CLUTCH	2	
31	21387	ENGINE, 4 HP. HONDA GX120K1QX2	1	
32	21674	BRACKET, PULLEY GUARD	1	
33	21675	PULLEY AK-32 X 3/4	1	
34	21713	CLUTCH BRACKET	1	
35	30102-001	BELT GUARD .....	1	..... SAFETY ITEM
36	933242	WASHER, FLAT SAE 3/8 GRD 9 YZ	2	

# CA4HMTROWEL — GUARD RING ASSY.

GUARD RING ASSY.

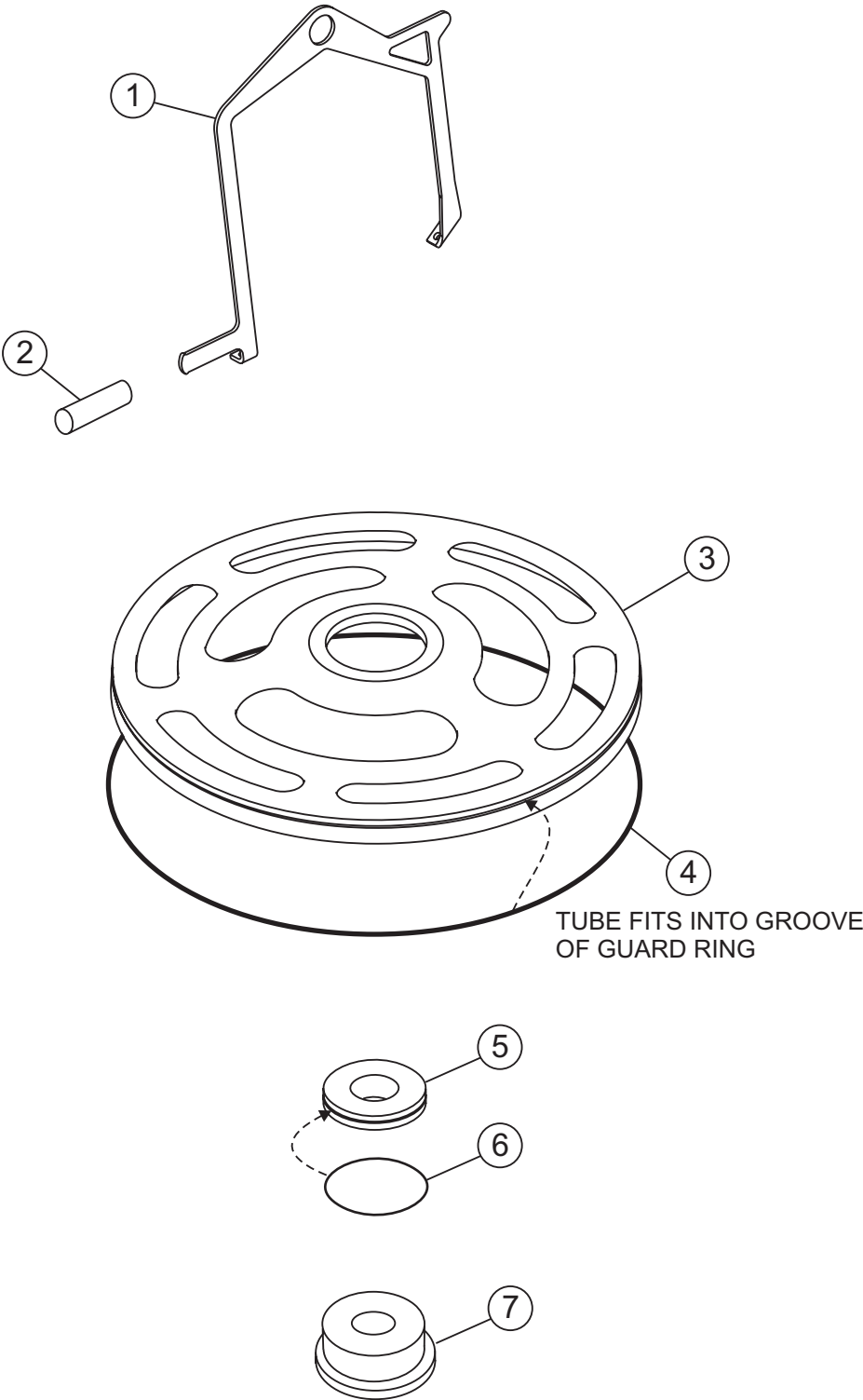

# CA4HM TROWEL — GUARD RING ASSY.

## GUARD RING ASSY.

<u>NO.</u>	<u>PART NO.</u>	<u>PART NAME</u>	<u>QTY.</u>	<u>REMARKS</u>
1	21502	LIFTING BALE .....	1 .....	ACCESSORY ITEM CONTACT UNIT SALES
2	1724	GRIP	1	
3	21433	GUARD RING	1	
4	21443	TUBE, GROOVE GUARD RING	1	
5	21441	BEARING .....	1 .....	INCLUDES ITEMS W/*
6*	21480	RING	1	
7	21434	SLEEVE, PITCH	1	

# CA4HMTROWEL — BLADES & PAN ASSY.

BLADES & PAN ASSY.

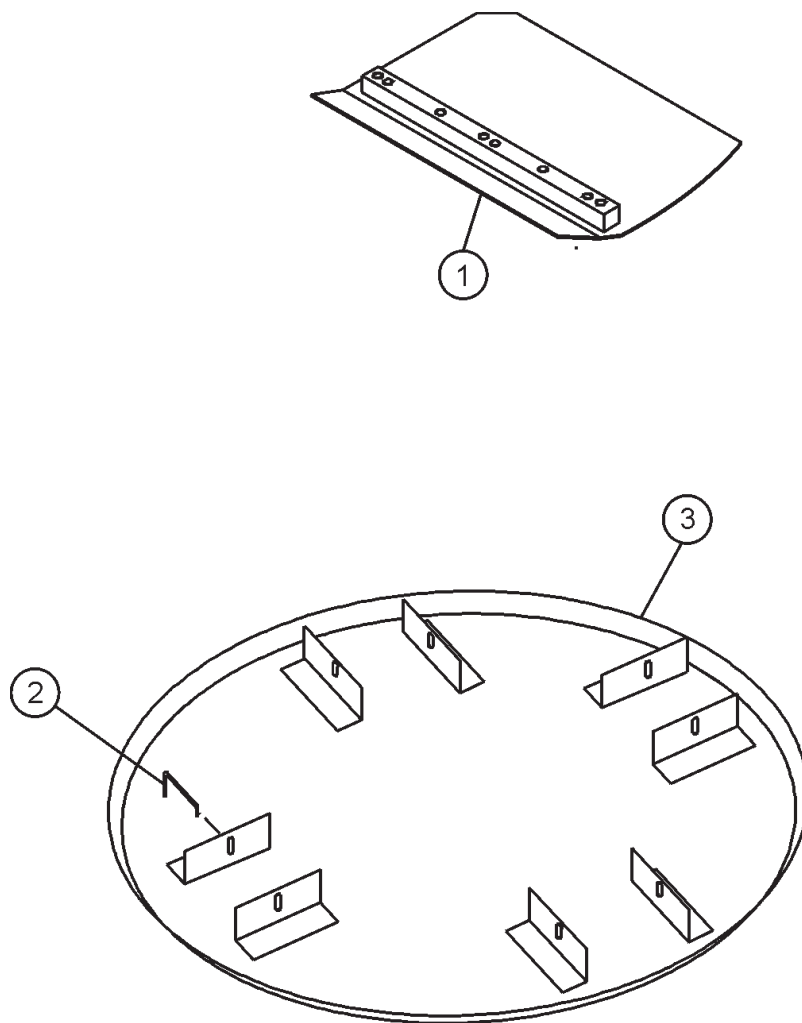

# CA4HM TROWEL — BLADES & PAN ASSY.

## BLADES & PAN ASSY.

<u>NO.</u>	<u>PART NO.</u>	<u>PART NAME</u>	<u>QTY.</u>	<u>REMARKS</u>
1		COMBO FLOAT & FINISH BLADE .....	4 .....	CONTACT UNIT SALES DEPT./ACCESSORY ITEM
2		FLOAT DISC LATCH PIN .....	4 .....	CONTACT UNIT SALES DEPT./ACCESSORY ITEM
3		FLOAT DISC .....	1 .....	CONTACT UNIT SALES DEPT./ACCESSORY ITEM

# HONDA GX120K1QX2 ENGINE — AIR CLEANER (DUAL) ASSY.

AIR CLEANER (DUAL) ASSY.

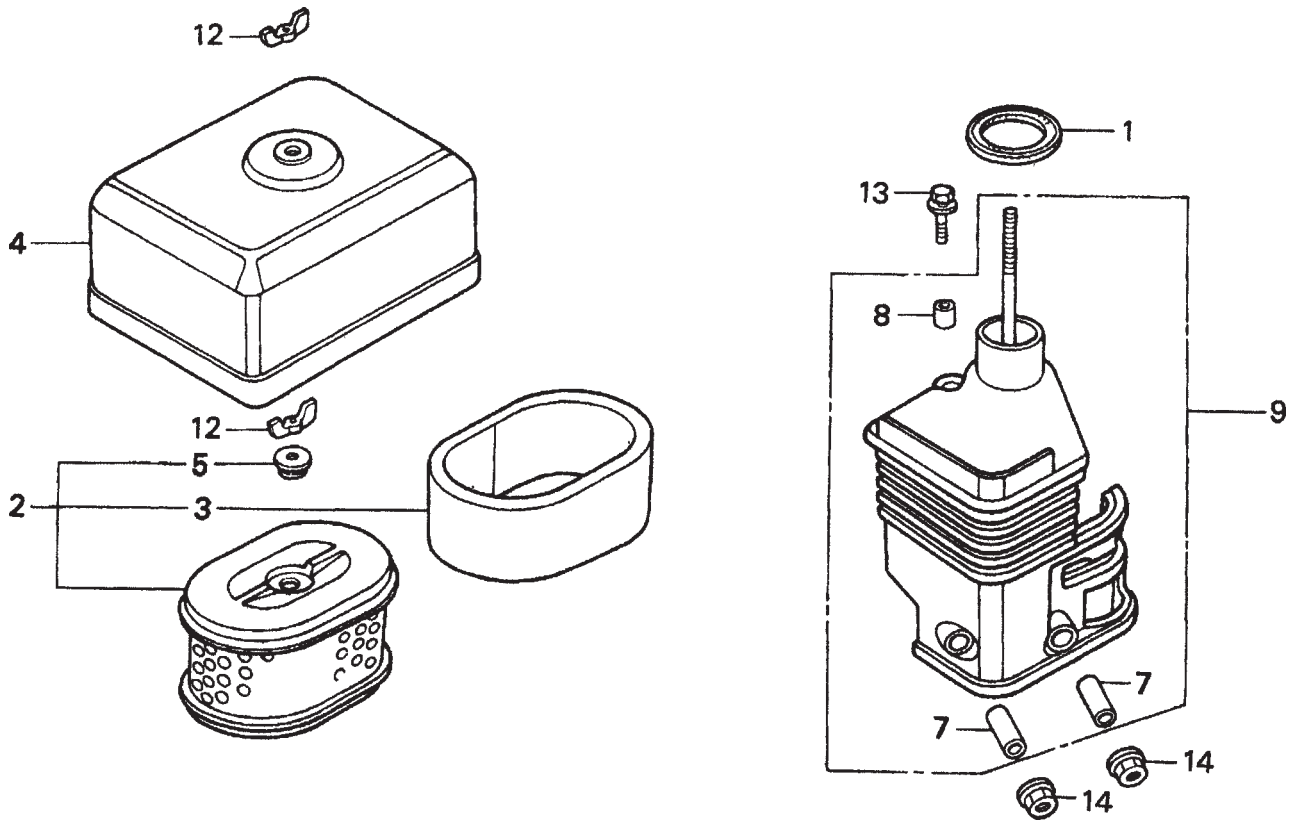



# HONDA GX120K1QX2 ENGINE — AIR CLEANER (DUAL) ASSY.

AIR CLEANER (DUAL) ASSY.

<u>NO.</u>	<u>PART NO.</u>	<u>PART NAME</u>	<u>QTY.</u>	<u>REMARKS</u>
1	16271ZE1000	GASKET, ELBOW	1	
2	17210ZE0505	ELEMENT, AIR CLEANER (DUAL) .....	1 .....	INCLUDES ITEMS W/*
3*	17218ZE0505	FILTER, OUTER	1	
4	17230ZE0820	COVER, AIR CLEANER (DUAL)	1	
5*	17232891000	GROMMET, AIR CLEANER	1	
7#	17238ZE0010	COLLAR, AIR CLEANER	2	
8#	17239ZE1000	COLLAR B, AIR CLEANER	1	
9	17410ZE0030	ELBOW, AIR CLEANER .....	1 .....	INCLUDES ITEMS W/#
12	90325044000	WINGNUT, TOOL BOX SETTING	2	
13	957010602000	BOLT, FLANGE 6X20	1	
14	9405006000	NUT, FLANGE 6MM	2	

# HONDA GX120K1QX2 ENGINE — CAMSHAFT ASSY.

CAMSHAFT ASSY.

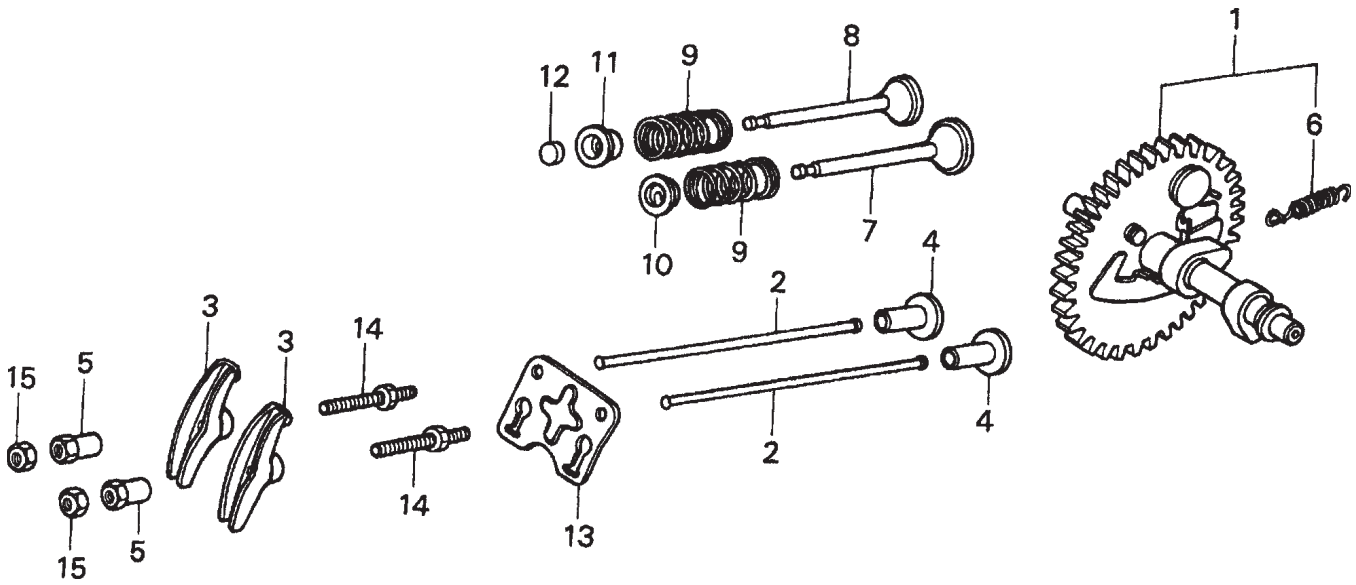

# HONDA GX120K1QX2 ENGINE — CAMSHAFT ASSY.

## CAMSHAFT ASSY.

<u>NO.</u>	<u>PART NO.</u>	<u>PART NAME</u>	<u>QTY.</u>	<u>REMARKS</u>
1	14100ZE0812	CAMSHAFT ASSEMBLY .....	1 .....	INCLUDES ITEMS W/*
2	14410ZE0010	ROD, PUSH	2	
3	14431ZE1000	ARM, VALVE ROCKER	2	
4	14441ZE1010	LIFTER, VALVE	2	
5	14451ZE1013	PIVOT, ROCKER ARM	2	
6*	14568ZE1000	SPRING, WEIGHT RETURN	1	
7	14711ZF0010	VALVE, IN.	1	
8	14721ZH7810	VALVE, EX. (HAUST)	1	
9	14751ZF1000	SPRING, VALVE	2	
10	14771ZE1000	RETAINER, IN. VALVE SPRING	1	
11	14773ZE1000	RETAINER, EX. VALVE SPRING	1	
12	14781ZE1000	ROTATOR, VALVE	1	
13	14791ZE0010	PLATE, PUSH ROD GUIDE	1	
14	90012ZE0010	BOLT, PIVOT 8MM	2	
15	90206ZE1000	NUT, PIVOT ADJ.	2	

# HONDA GX120K1QX2 ENGINE — CARBURETOR ASSY.

CARBURETOR ASSY.

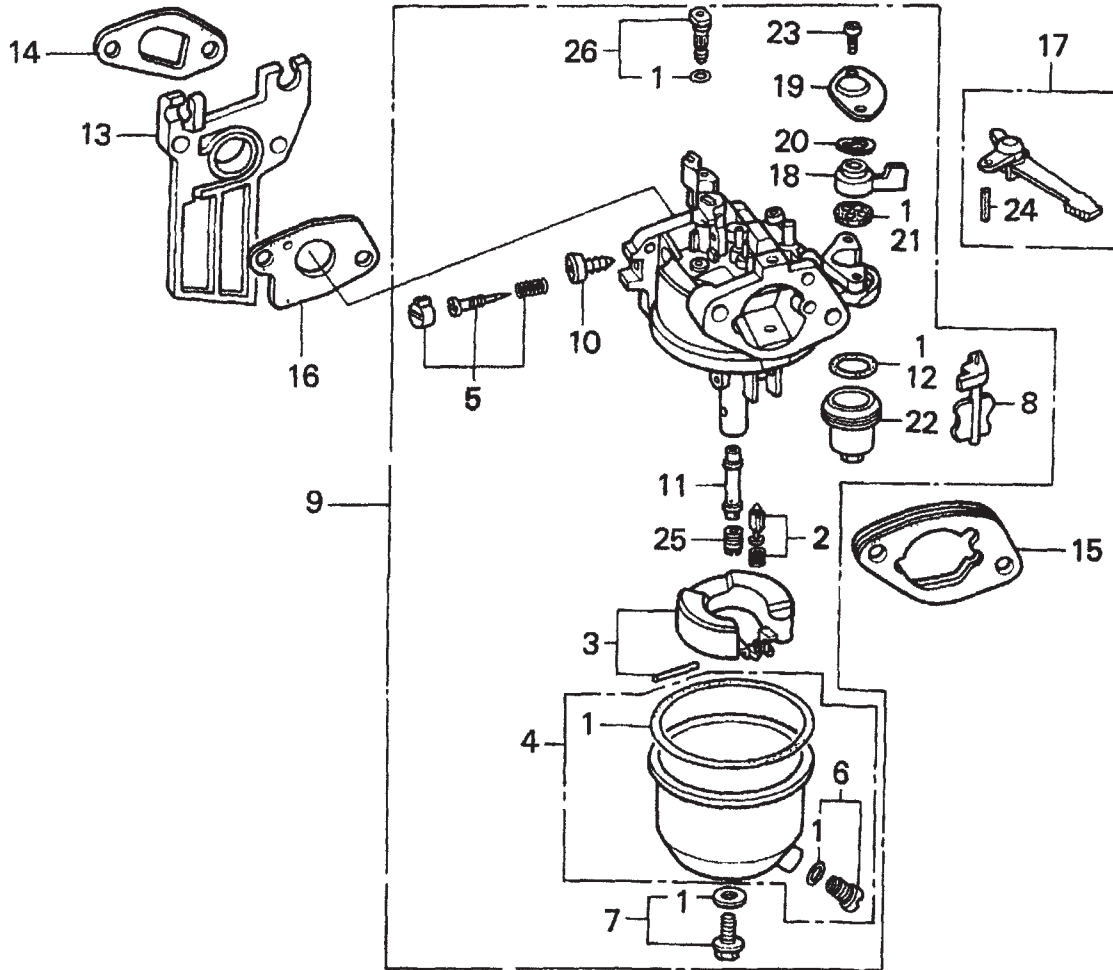

# HONDA GX120K1QX2 ENGINE — CARBURETOR ASSY.

## CARBURETOR ASSY.

<u>NO.</u>	<u>PART NO.</u>	<u>PART NAME</u>	<u>QTY.</u>	<u>REMARKS</u>
1*	16010ZE1812	GASKET SET	1	
2*	16011ZE0005	VALVE SET, FLOAT	1	
3*	16013ZE0005	FLOAT SET	1	
4*	16015ZE1811	CHAMBER SET, FLOAT	1	
5*	16016ZH7W01	SCREW SET	1	
6*	16024ZE1811	SCREW SET, DRAIN	1	
7*	16028ZE0005	SCREW SET B	1	
8*	16044ZE0005	CHOKE SET	1	
9	16100ZH8W51	CARBURETOR ASSY. (BE65B B) .....	1	..... INCLUDES ITEMS W/*
10*	16124ZE0005	SCREW, THROTTLE STOP	1	
11*	16166ZH7W50	NOZZLE, MAIN	1	
12*	16173001004	O-RING	1	
13	16211ZE1000	INSULATOR, CARBURETOR	1	
14	16212ZH7800	GASKET, INSULATOR	1	
15	16220ZE1020	SPACER, CARBURETOR	1	
16	16221ZH8801	GASKET, CARBURETOR	1	
17	16610ZE1000	LEVER, CHOKE (STD) .....	1	..... INCLUDES ITEMS W/#
18*	16953ZE1812	LEVER, VALVE	1	
19*	16954ZE1811	PLATE, LEVER SETTING	1	
20*	16956ZE1811	SPRING, VALVE LEVER	1	
21*	16957ZE1812	GASKET, VALVE	1	
22*	16967ZE0811	CUP, FUEL STRAINER	1	
23*	93500030080G	SCREW, PAN (3 X 6)	2	
24#	9430520122	PIN, SPRING (2 X 12)	1	
25	99101ZH80550	JET, MAIN (#55) OPTIONAL	1	
25	99101ZH80580	JET, MAIN (#58) OPTIONAL	1	
25*	99101ZH80600	JET, MAIN (#60)	1	
26*	99204ZE00350	JET, SET, PILOT (#35)	1	

# HONDA GX120K1QX2 ENGINE — CONTROL ASSY.

CONTROL ASSY.

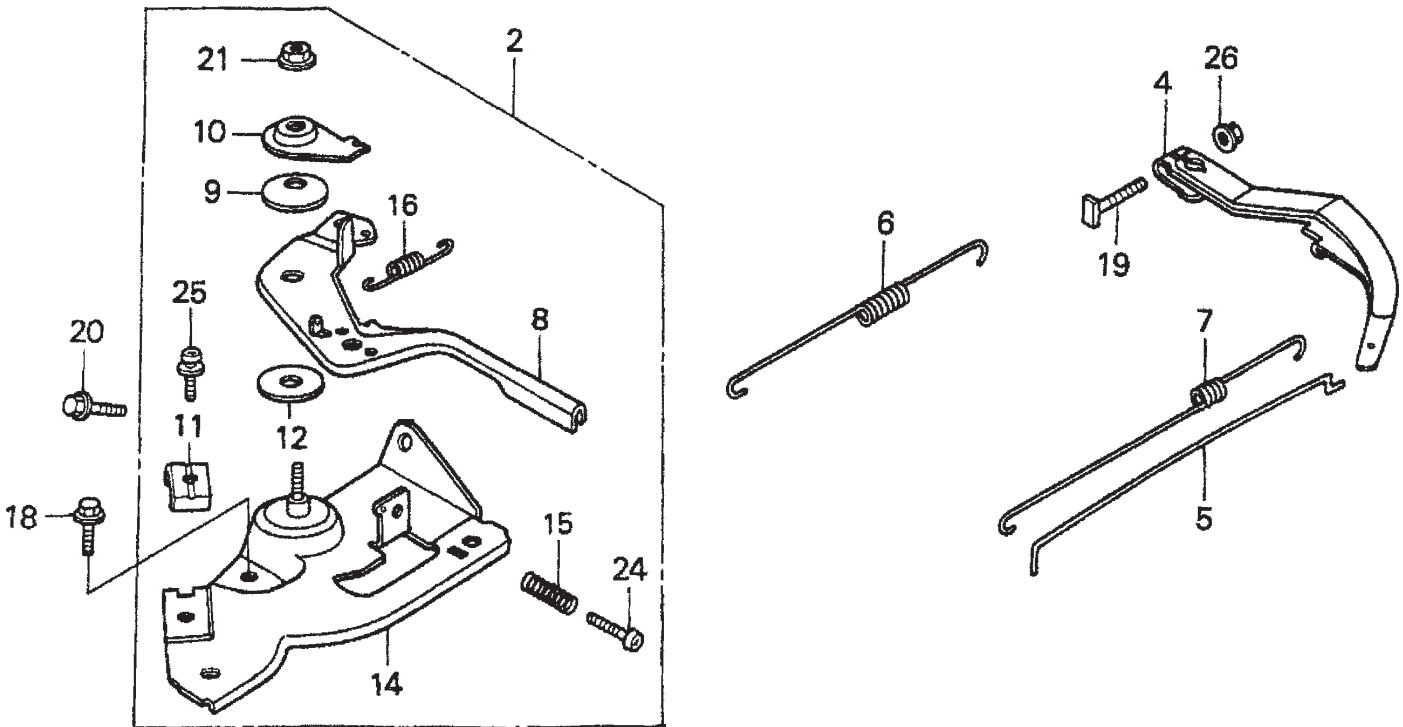

# HONDA GX120K1QX2 ENGINE — CONTROL ASSY.

## CONTROL ASSY.

<u>NO.</u>	<u>PART NO.</u>	<u>PART NAME</u>	<u>QTY.</u>	<u>REMARKS</u>
2	16500ZH7820	CONTROL ASSEMBLY .....	1 .....	INCLUDES ITEMS W/*
4	16551ZE0010	ARM, GOVERNOR	1	
5	16555ZE0000	ROD, GOVERNOR	1	
6	16561ZE0020	SPRING, GOVERNOR	1	
7	16562ZE0020	SPRING, THROTTLE RETURN	1	
8*	16571ZH7000	LEVER, CONTROL	1	
9*	16574ZE1000	SPRING, LEVER	1	
10*	16575ZH8000	WASHER, CONTROL LEVER	1	
11*	16576891000	HOLDER, CABLE	1	
12*	16578ZE1000	SPACER, CONTROL LEVER	1	
14*	16580ZH7810	BASE, CONTROL	1	
15*	16584883300	SPRING, CONTROL ADJUSTING	1	
16*	16592ZE1810	SPRING, CABLE RETURN	1	
18	90013883000	BOLT, FLANGE 6X12 (CT200)	1	
19	90015ZE5010	BOLT, GOVERNOR ARM	1	
20	90022888010	BOLT, FLANGE 6X20 (CT200)	1	
21*	90114SA0000	NUT, SELF- LOCK 6MM	1	
24*	93500050250H	SCREW, PAN 5X25	1	
25*	93500050160A	SCREW-WASHER (5X16)	1	
26	9405006000	NUT, FLANGE 6MM	1	

# HONDA GX120K1QX2 ENGINE — CRANKCASE COVER ASSY.

CRANKCASE COVER ASSY.

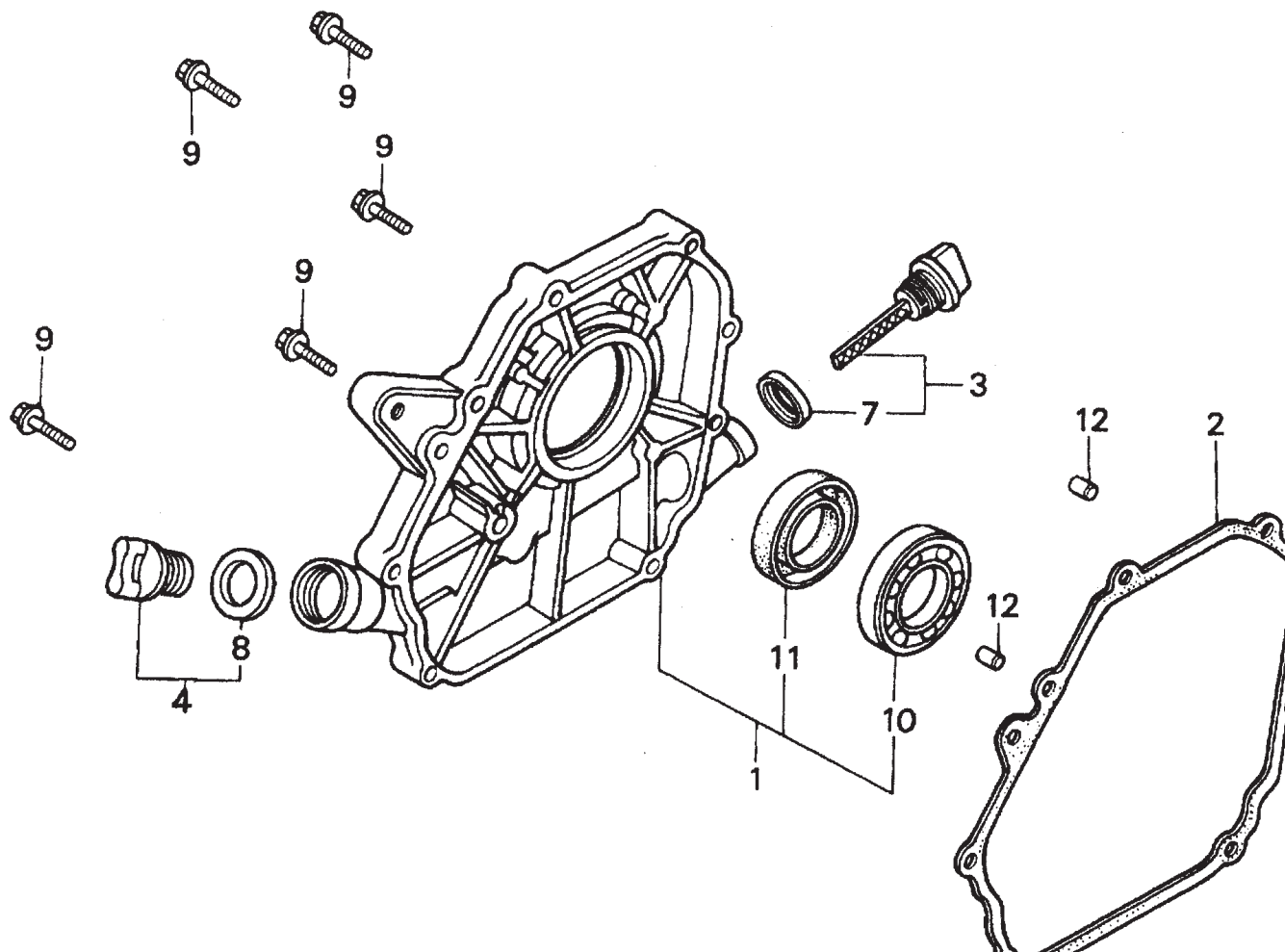



# HONDA GX120K1QX2 ENGINE — CRANKCASE COVER ASSY.

## CRANKCASE COVER ASSY.

<u>NO.</u>	<u>PART NO.</u>	<u>PART NAME</u>	<u>QTY.</u>	<u>REMARKS</u>
1	11300ZE0640	COVER ASSEMBLY, CRANKCASE (U- TYPE) .....	1 .....	INCLUDES ITEMS W/%
2	11381ZH7800	GASKET, CASE COVER	1	
3	15600ZE1003	CAP ASSEMBLY, OIL FILLER .....	1 .....	INCLUDES ITEMS W/#
4	15600ZG4003	CAP ASSEMBLY, OIL FILLER .....	1 .....	INCLUDES ITEMS W/*
7#	15625ZE1003	GASKET, OIL FILLER CAP	1	
8*	15625ZE1003	GASKET, OIL FILLER CAP	1	
9	90015883000	BOLT, FLANGE 6X28	7	
10%	91001878003	BEARING, RADIAL BALL	1	
11%	91203ZE0003	OIL SEAL 22X41X6	1	
12	9430108140	PIN A, DOWEL 8X14	2	

# HONDA GX120K1QX2 ENGINE — CRANKSHAFT ASSY.

CRANKSHAFT ASSY.

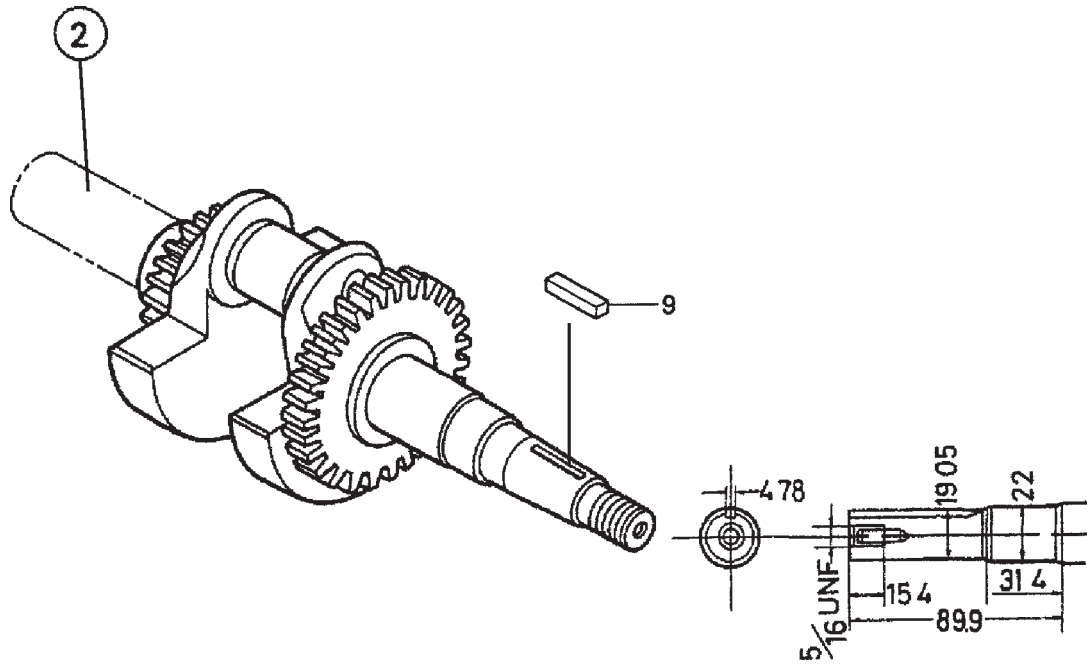

# HONDA GX120K1QX2 ENGINE — CRANKSHAFT ASSY.

CRANKSHAFT ASSY.

<u>NO.</u>	<u>PART NO.</u>	<u>PART NAME</u>	<u>QTY.</u>	<u>REMARKS</u>
6	13310ZE0650	CRANKSHAFT, Q-TYPE	1	
9	90745ZE1600	KEY (4.78 X 78 X 38)		

# HONDA GX120K1QX2 ENGINE — CYLINDER BARREL ASSY.

CYLINDER BARREL ASSY.

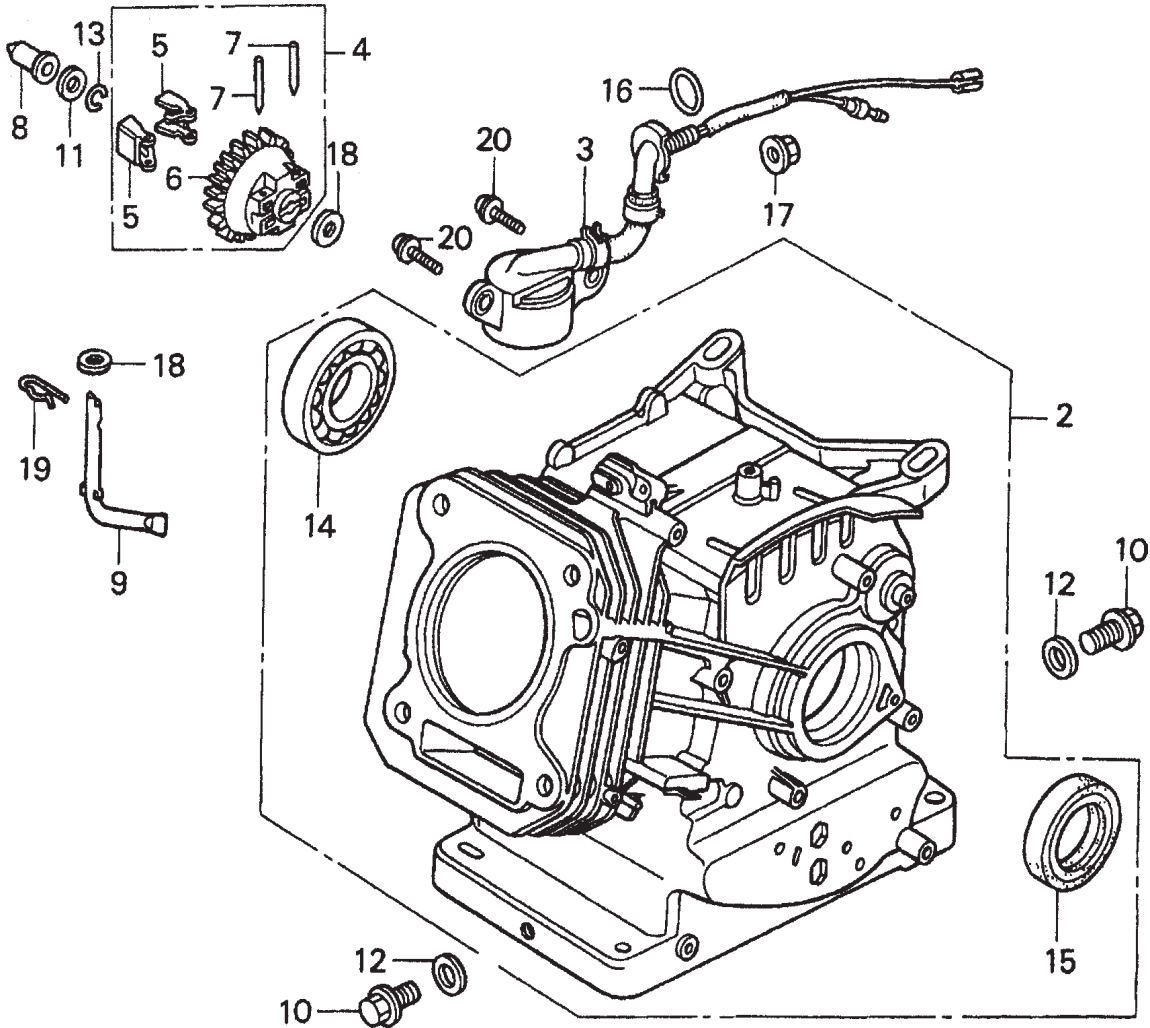

# HONDA GX120K1QX2 ENGINE — CYLINDER BARREL ASSY.

## CYLINDER BARREL ASSY.

<u>NO.</u>	<u>PART NO.</u>	<u>PART NAME</u>	<u>QTY.</u>	<u>REMARKS</u>
2	12000ZH7415	CYLINDER ASSEMBLY, 811 (OIL ALERT) .....	1 .....	INCLUDES ITEMS W/*
3	15510ZE1033	SWITCH ASSEMBLY, OIL LEVEL	1	
4	16510ZE1000	GOVERNOR ASSEMBLY .....	1 .....	INCLUDES ITEMS W/#
5#	16511ZE1000	WEIGHT, GOVERNOR	2	
6#	16512ZE1000	HOLDER, GOVERNOR WEIGHT	1	
7#	16513ZE1000	PIN, GOVERNOR WEIGHT	2	
8	16531ZE1000	SLIDER, GOVERNOR	1	
9	16541ZE1000	SHAFT, GOVERNOR ARM	1	
10	90131ZE1000	BOLT, DRAIN PLUG	2	
11	90451ZE1000	WASHER, THRUST 6MM	1	
12	90601ZE1000	WASHER, DRAIN PLUG 10.2MM	2	
13	90602ZE1000	CLIP, GOVERNOR HOLDER	1	
14*	91001878003	BEARING, RADIAL BALL 62/22	1	
15*	91202ZE6003	OIL SEAL 22X35X6	1	
16	91353671003	O- RING 13.5X1.5 (ARAI)	1	
17	9405010000	NUT, FLANGE 10MM	1	
18	9410106800	WASHER, PLAIN 6MM	2	
19	9425108000	PIN, LOCK 8MM	1	
20	957010601200	BOLT, FLANGE 6X12	2	

# HONDA GX120K1QX2 ENGINE — CYLINDER HEAD ASSY.

CYLINDER HEAD ASSY.

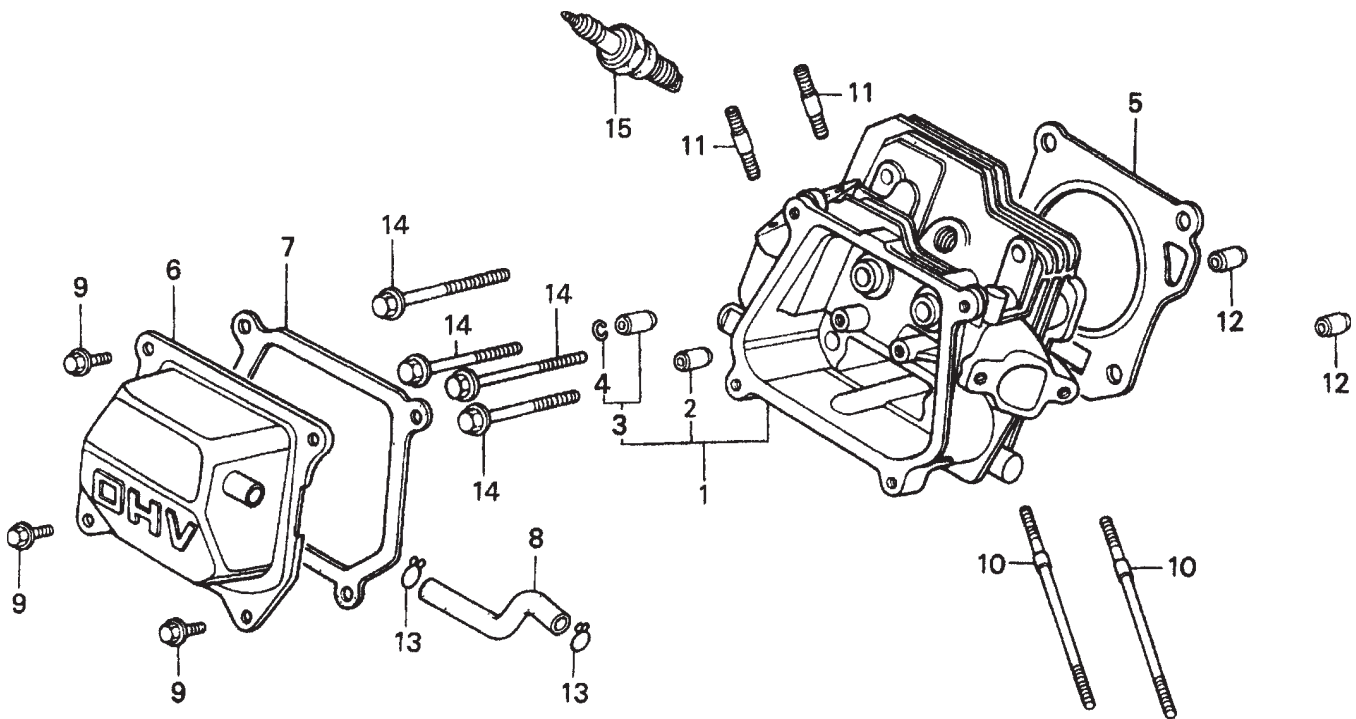

# HONDA GX120K1QX2 ENGINE — CYLINDER HEAD ASSY.

## CYLINDER HEAD ASSY.

<u>NO.</u>	<u>PART NO.</u>	<u>PART NAME</u>	<u>QTY.</u>	<u>REMARKS</u>
1	12210ZH7000	CYLINDER HEAD .....	1 .....	INCLUDES ITEMS W/*
2*	12204ZE1306	GUIDE, VALVE (OS) OPTIONAL	1	
3*	12205ZE1315	GUIDE, EX. VALVE (OS) OPTIONAL .....	1 .....	INCLUDES ITEMS W/#
4*#	12216ZE5300	CLIP, VALVE GUIDE	1	
5	12251ZH7800	GASKET, CYLINDER HEAD	1	
6	12310ZE1000	COVER, HEAD	1	
6	12310ZE1010	COVER, HEAD	1	
7	12391ZE1000	GASKET, CYLINDER HEAD COVER	1	
8	15721ZH8000	TUBE, BREATHER	1	
9	90013883000	BOLT, FLANGE 6X12 (CT200)	4	
10	90043ZE1020	BOLT, STUD 6X109	2	
11	90047ZE1000	BOLT, STUD 8X32	2	
12	9430110160	PIN, A, DOWEL 10X16	2	
14	957230805500	BOLT, FLANGE 8X55	4	
15	9807955855	SPARK PLUG W16EPR- U (DENSO), OPT.	1	
15	9807956846	SPARK PLUG BPR6ES, (NGK)	1	

# HONDA GX120K1QX2 ENGINE — FAN COVER ASSY.

FAN COVER ASSY.

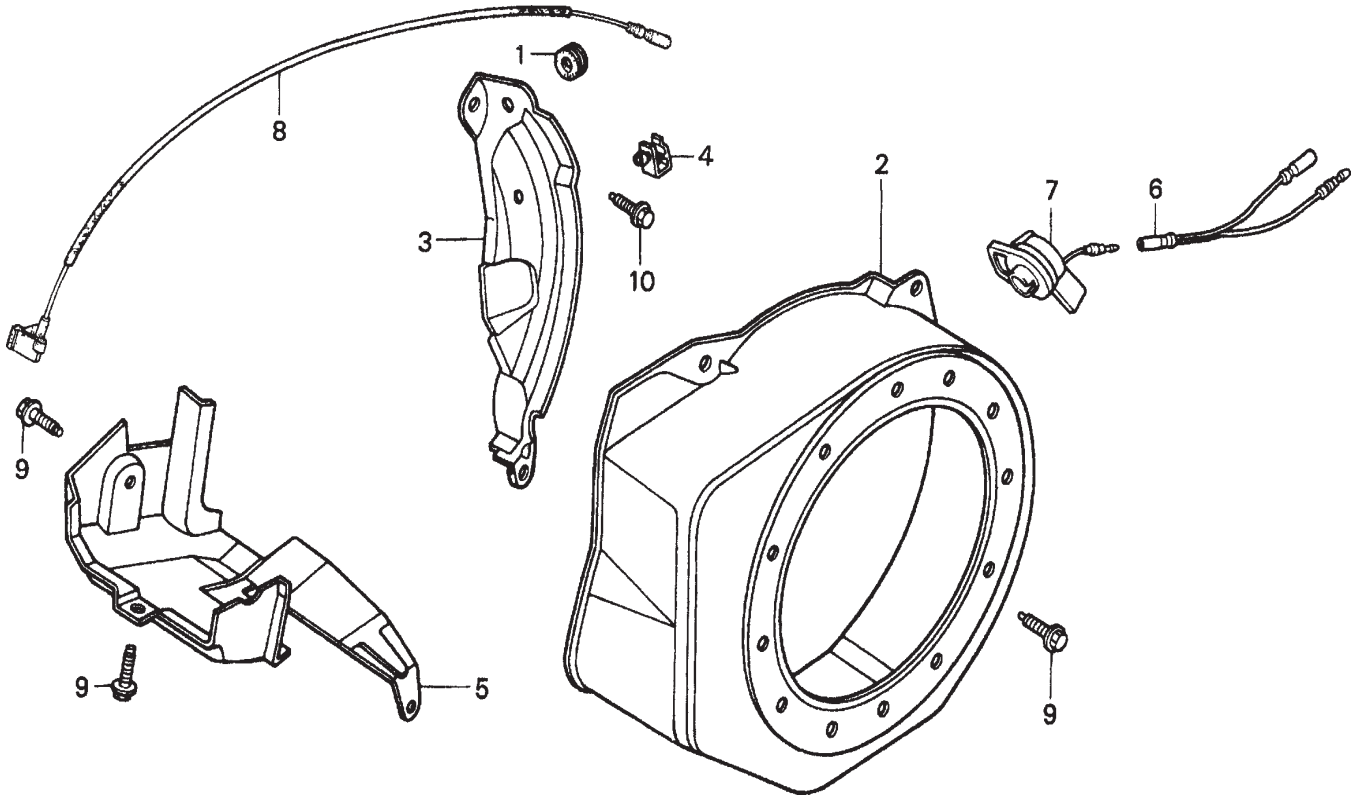



## HONDA GX120K1QX2 ENGINE — FAN COVER ASSY.

FAN COVER ASSY.

<u>NO.</u>	<u>PART NO.</u>	<u>PART NAME</u>	<u>QTY.</u>	<u>REMARKS</u>
1	11347371300	GROMMET, ADJUSTING COVER	1	
2	19610ZE0000ZE	COVER, FAN *NH1* BLACK	1	
3	19612ZH7810	PLATE, SIDE (OIL ALERT)	1	
4	90601ZH7013	CLIP, HARNESS	1	
5	19630ZH7000	SHROUD	1	
6	32197ZH8003	SUB- HARNESS	1	
7	36100ZH7003	SWITCH ASSEMBLY, ENGINE STOP	1	
8	36101ZE1010	WIRE, STOP SWITCH 370MM	1	
9	90013883000	BOLT, FLANGE 6X12 (CT200)	6	
10	90022888010	BOLT, FLANGE 6X12 (CT200)	1	
11	34150ZH7003	ALERT UNIT, OIL	1	
13	957010600800	BOLT, FLANGE 6X8	1	

# HONDA GX120K1QX2 ENGINE — FLYWHEEL ASSY.

FLYWHEEL ASSY.

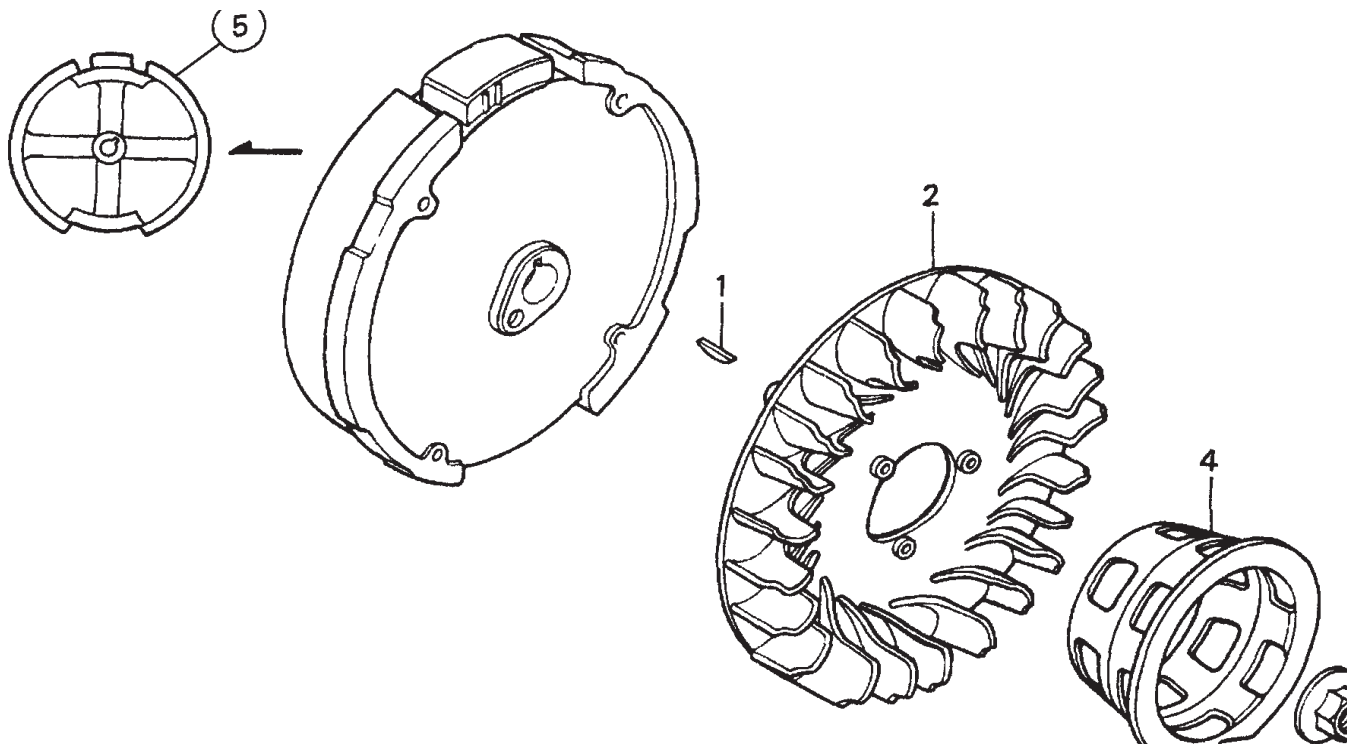

## HONDA GX120K1QX2 ENGINE — FLYWHEEL ASSY.

FLYWHEEL ASSY.

<u>NO.</u>	<u>PART NO.</u>	<u>PART NAME</u>	<u>QTY.</u>	<u>REMARKS</u>
1	13331357000	KEY, SPECIAL WOODRUFF 25X18	1	
2	19511ZE0000	FAN, COOLING	1	
4	28451ZH8003	PULLEY, STARTER	1	
5	31100ZE0010	FLYWHEEL	1	
7	90201878003	NUT, SPECIAL 14MM	1	

# HONDA GX120K1QX2 ENGINE — FUEL TANK ASSY.

FUEL TANK ASSY.

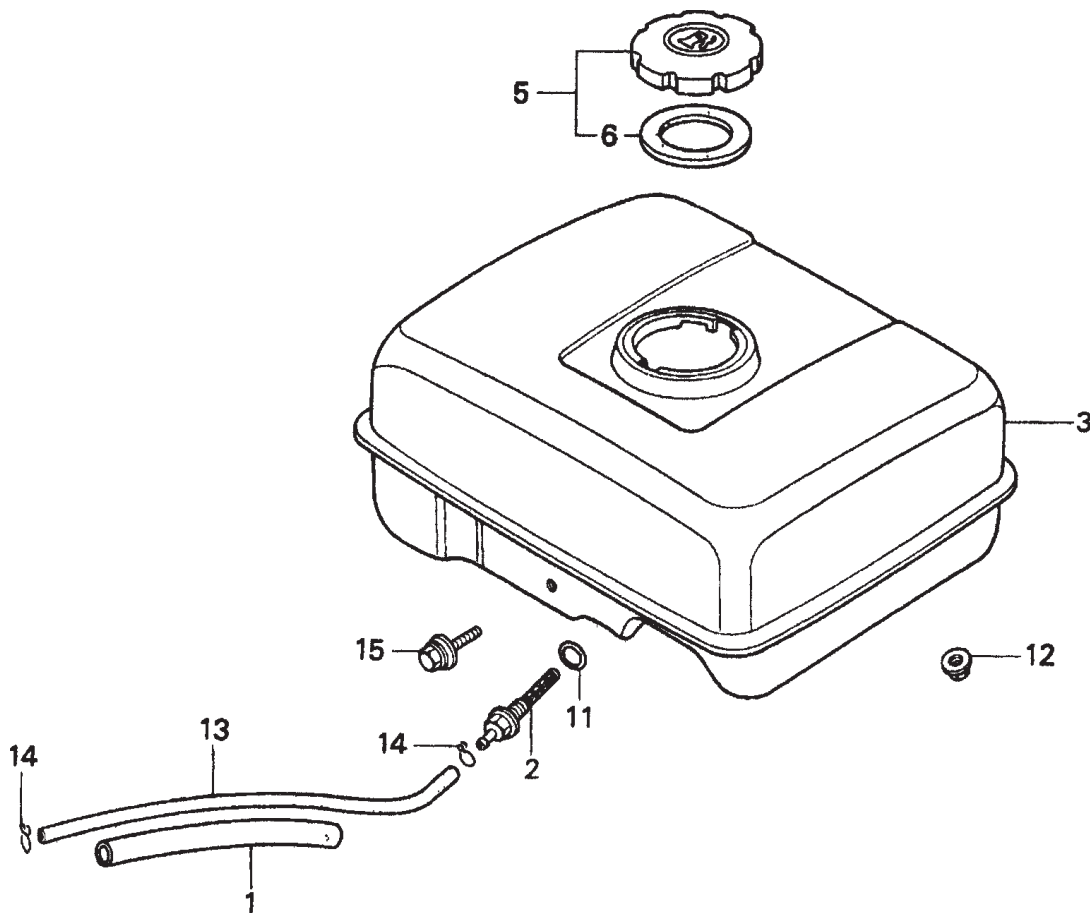

# HONDA GX120K1QX2 ENGINE — FUEL TANK ASSY.

## FUEL TANK ASSY.

<u>NO.</u>	<u>PART NO.</u>	<u>PART NAME</u>	<u>QTY.</u>	<u>REMARKS</u>
1	16854ZH8000	RUBBER, SUPPORTER 107MM	1	
2	16955ZE1000	JOINT, FUEL TANK	1	
3	17510ZE0020ZD	TANK, FUEL *NH1* (BLACK)	1	
5	17620ZH7023	CAP, FUEL FILLER .....	1	INCLUDES ITEMS W/*
6*	17631ZH7003	GASKET, FUEL FILLER CAP	1	
11	91353671003	O- RING 13.5X1.5 (ARAI)	1	
12	9405006000	NUT, FLANGE 6MM	2	
13	950014500360M	BULK HOSE, FUEL (4.5X3000) (4.5X140)	1	
14	9500202080	CLIP, TUBE (B8)	2	
15	90004ZH7003	BOLT, FLANGE 6X29	1	

# HONDA GX120K1QX2 ENGINE — IGNITION COIL ASSY.

IGNITION COIL ASSY.

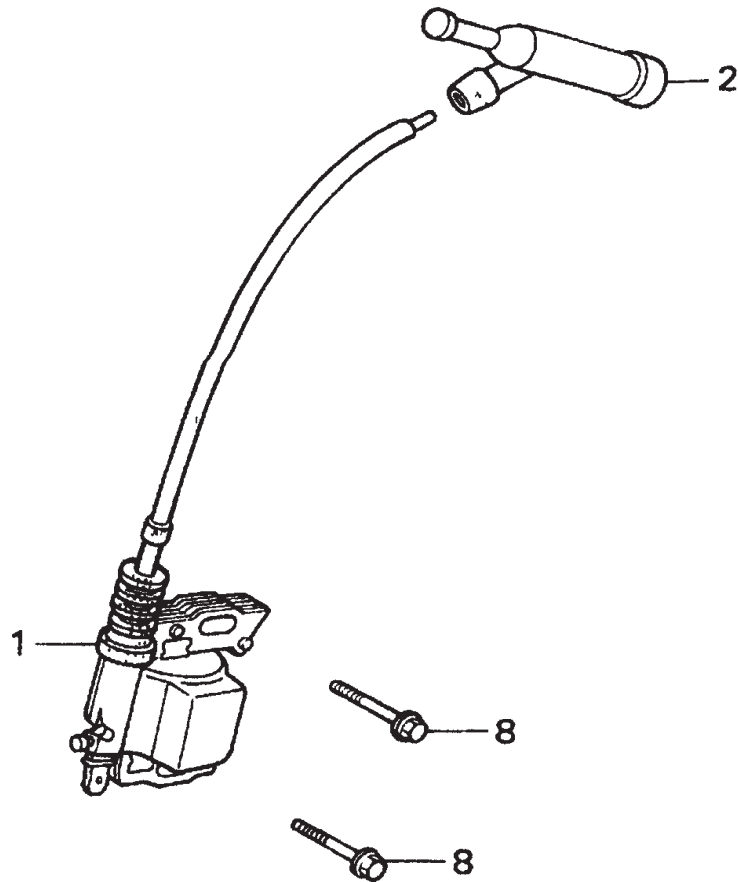

# HONDA GX120K1QX2 ENGINE — IGNITION COIL ASSY.

## IGNITION COIL ASSY.

<u>NO.</u>	<u>PART NO.</u>	<u>PART NAME</u>	<u>QTY.</u>	<u>REMARKS</u>
1	30500ZE1033	COIL ASSEMBLY, IGNITION	1	
2	30700ZE1013	CAP ASSEMBLY, NOISE SUPPRESSOR	1	
8	90121952000	BOLT, FLANGE 6X25	2	

# HONDA GX120K1QX2 ENGINE — MUFFLER ASSY.

MUFFLER ASSY.

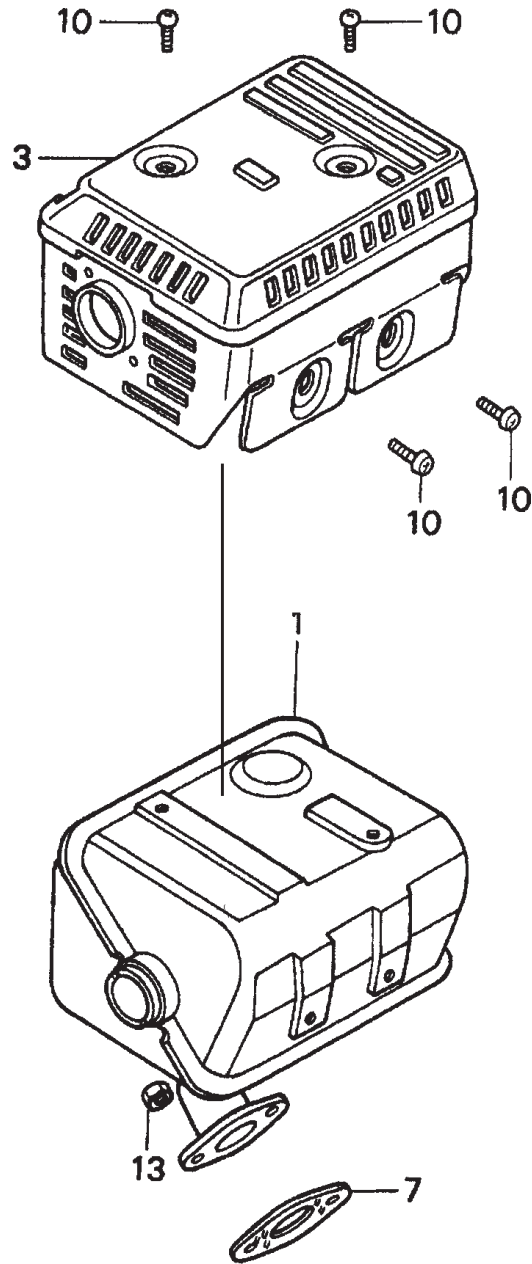



## HONDA GX120K1QX2 ENGINE — MUFFLER ASSY.

MUFFLER ASSY.

<u>NO.</u>	<u>PART NO.</u>	<u>PART NAME</u>	<u>QTY.</u>	<u>REMARKS</u>
1	18310ZF1000	MUFFLER	1	
3	18320ZF1H01	PROTECTOR, MUFFLER	1	
7	18381ZH8800	GASKET, MUFFLER	1	
10	90050ZE1000	SCREW, TAPPING 5X8	4	
13	94001080000S	NUT, HEX. 8MM	2	

# HONDA GX120K1QX2 ENGINE — PISTON ASSY.

PISTON ASSY.

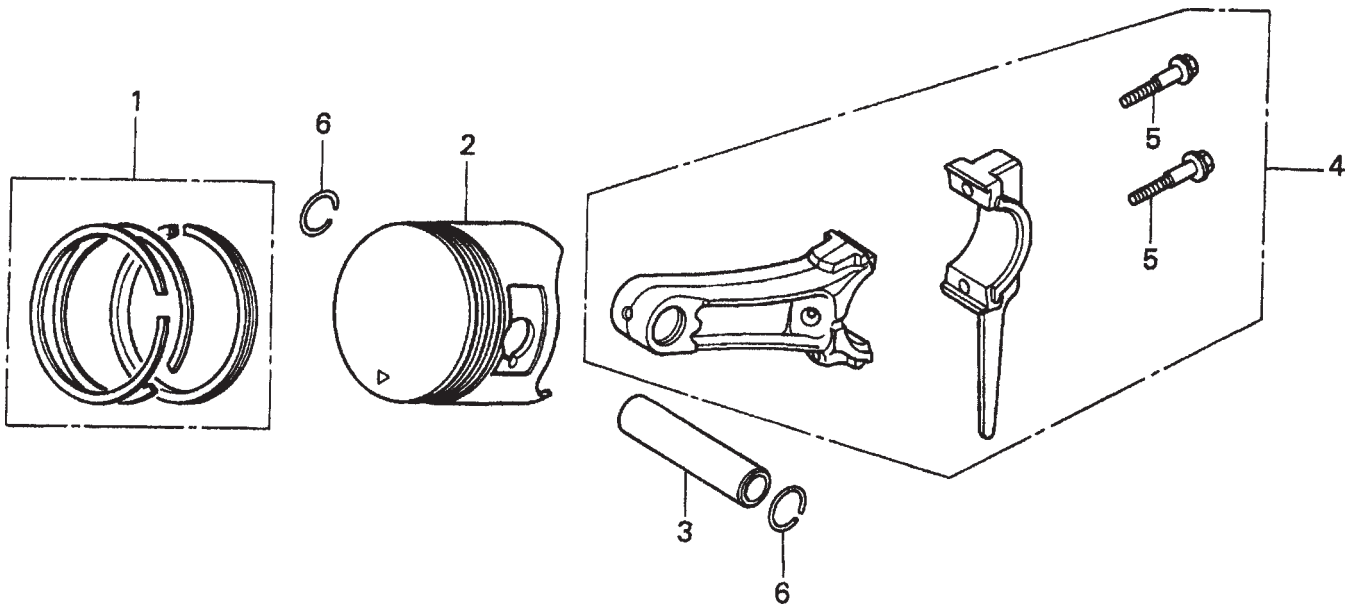

# HONDA GX120K1QX2 ENGINE — PISTON ASSY.

PISTON ASSY.

<u>NO.</u>	<u>PART NO.</u>	<u>PART NAME</u>	<u>QTY.</u>	<u>REMARKS</u>
1	13010ZK7V01	RING SET, PISTON (STANDARD)	1	
1	13011ZK7V01	RING SET, PISTON (OS 0.25), OPTIONAL	1	
1	13012ZK7V01	RING SET, PISTON (OS 0.50), OPTIONAL	1	
1	13013ZK7V01	RING SET, PISTON (0.75), OPTIONAL	1	
2	13101ZH7000	PISTON, STANDARD	1	
2	13102ZH7000	PISTON, OS 0.25 (OPTIONAL)	1	
2	13103ZH7000	PISTON, OS 0.50 (OPTIONAL)	1	
2	13104ZH7000	PISTON, 0.75 (OPTIONAL)	1	
3	13111ZE0000	PIN, PISTON	1	
4	132A0ZE0000	ROD ASSY., CONNECTING (UNDERSIZE) OPTIONAL ....	1	INCLUDES ITEMS W/*
4	13200ZE0000	ROD ASSEMBLY, CONNECTING .....	1	INCLUDES ITEMS W/*
5*	90001ZE1000	BOLT, CONNECTING ROD	2	
6	90551ZE0000	CLIP, PISTON PIN 13MM	2	

# HONDA GX120K1QX2 ENGINE — RECOILSTARTER ASSY.

RECOIL STARTER ASSY.

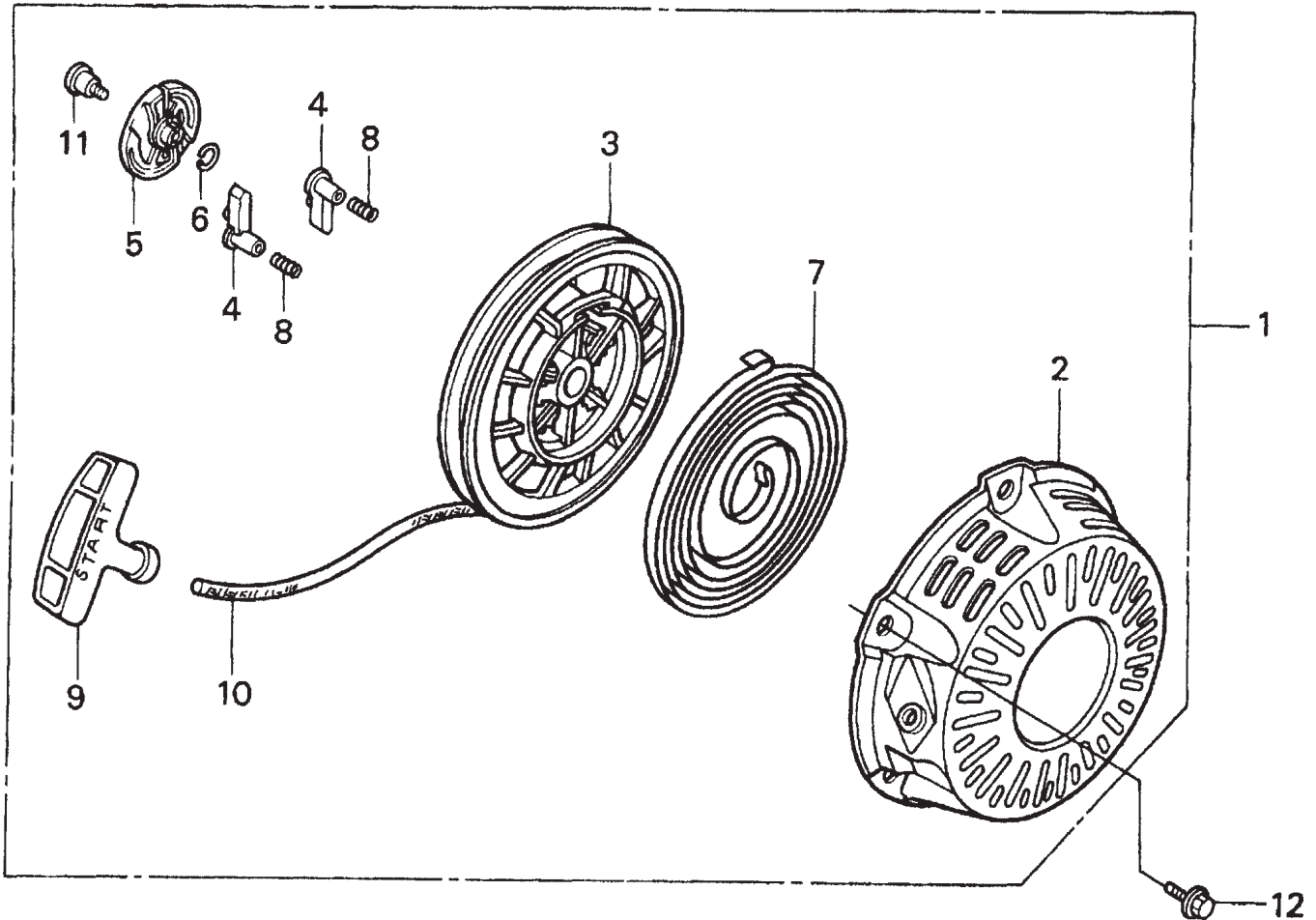

# HONDA GX120K1QX2 ENGINE — RECOILSTARTER ASSY.

## RECOIL STARTER ASSY.

<u>NO.</u>	<u>PART NO.</u>	<u>PART NAME</u>	<u>QTY.</u>	<u>REMARKS</u>
1	28400ZH8013ZB	STARTER ASSY., RECOIL *NH1* (BLACK) .....	1 .....	INCLUDES ITEMS W/*
2*	28410ZH8003ZB	CASE, RECOIL STARTER	1	
3*	28420ZH8013	REEL, RECOIL STARTER	1	
4*	28422ZH8013	RATCHET, STARTER	2	
5 *	28433ZH8003	GUIDE, RATCHET	1	
6*	28441ZH8003	SPRING, FRICTION	1	
7*	28442ZH8003	SPRING, RECOIL STARTER	1	
8*	28443ZH8003	SPRING, RETURN	2	
9*	28461ZH8003	KNOB, RECOIL STARTER	1	
10*	28462ZH8003	ROPE, RECOIL STARTER	1	
11*	90003ZH8003	SCREW, SETTING	1	
12	90008ZE2003	BOLT, FLANGE 6X10	3	

GASKET KIT ASSY.

**NO ART WORK**

# HONDA GX120K1QX2 ENGINE — GASKET KIT ASSY.

## GASKET KIT ASSY.

<u>NO.</u>	<u>PART NO.</u>	<u>PART NAME</u>	<u>QTY.</u>	<u>REMARKS</u>
1	06111ZH7405	GASKET KIT .....	1 .....	INCLUDES ITEMS W/*
2*	11381ZH7800	GASKET, CASE COVER	1	
3*	12251ZH7800	GASKET, CYLINDER HEAD	1	
4*	12391ZE1000	GASKET, CYLINDER HEAD COVER	1	
5*	16212ZH7800	GASKET, INSULATOR	1	
6*	16221ZH8801	GASKET, CARBURETOR	1	
7*	18381ZH8800	GASKET, MUFFLER	1	

# HONDA GX120K1QX2 ENGINE — LABELS ASSY.

LABELS ASSY.

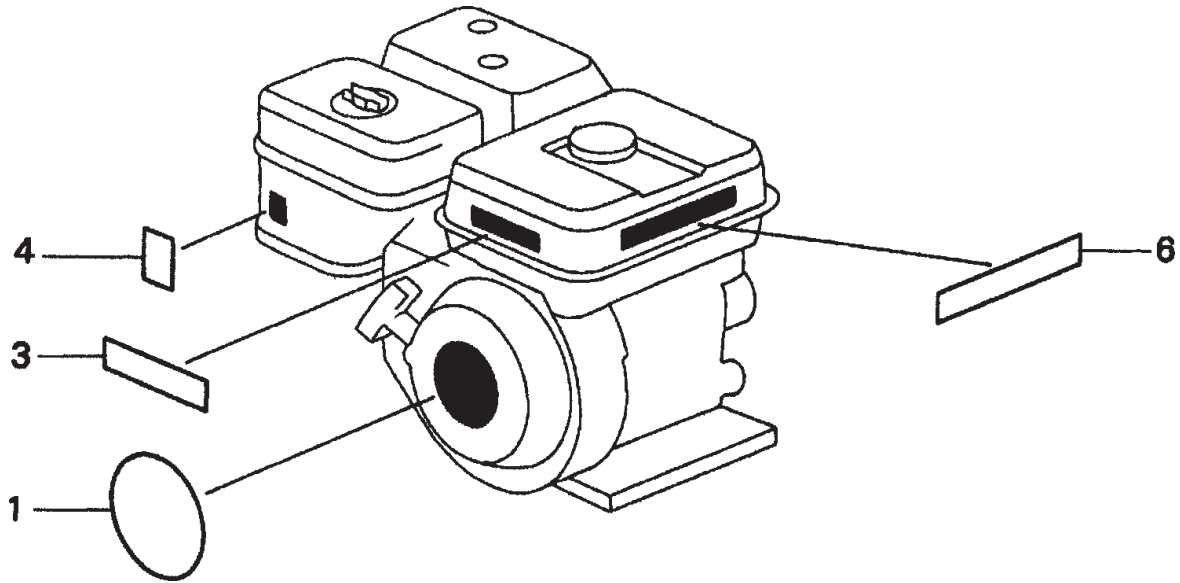



## HONDA GX120K1QX2 ENGINE — LABELS ASSY.

LABELS ASSY.

<u>NO.</u>	<u>PART NO.</u>	<u>PART NAME</u>	<u>QTY.</u>	<u>REMARKS</u>
1	87521ZH7020	EMBLEM	1	
3	87522ZH9000	LABEL, CAUTION	1	
4	87528ZE1810	MARK, CHOKE	1	
6	87532ZH8810	MARK, OIL ALERT (E)	1	

**PAYMENT TERMS**

Terms of payment for parts are net 30 days.

**FREIGHT POLICY**

All parts orders will be shipped collect or prepaid with the charges added to the invoice. All shipments are F.O.B. point of origin. Multiquip's responsibility ceases when a signed manifest has been obtained from the carrier, and any claim for shortage or damage must be settled between the consignee and the carrier.

**MINIMUM ORDER**

The minimum charge for orders from Multiquip is \$15.00 net. Customers will be asked for instructions regarding handling of orders not meeting this requirement.

**RETURNED GOODS POLICY**

Return shipments will be accepted and credit will be allowed, subject to the following provisions:

1. A Returned Material Authorization must be approved by Multiquip prior to shipment.
2. To obtain a Return Material Authorization, a list must be provided to Multiquip Parts Sales that defines item numbers, quantities, and descriptions of the items to be returned.
  - a. The parts numbers and descriptions must match the current parts price list.
  - b. The list must be typed or computer generated.
  - c. The list must state the reason(s) for the return.
  - d. The list must reference the sales order(s) or invoice(s) under which the items were originally purchased.
  - e. The list must include the name and phone number of the person requesting the RMA.
3. A copy of the Return Material Authorization must accompany the return shipment.
4. Freight is at the sender's expense. All parts must be returned freight prepaid to Multiquip's designated receiving point.

5. Parts must be in new and resalable condition, in the original Multiquip package (if any), and with Multiquip part numbers clearly marked.
6. The following items are not returnable:
  - a. Obsolete parts. (If an item is in the price book and shows as being replaced by another item, it is obsolete.)
  - b. Any parts with a limited shelf life (such as gaskets, seals, "O" rings, and other rubber parts) that were purchased more than six months prior to the return date.
  - c. Any line item with an extended dealer net price of less than \$5.00.
  - d. Special order items.
  - e. Electrical components.
  - f. Paint, chemicals, and lubricants.
  - g. Decals and paper products.
  - h. Items purchased in kits.
7. The sender will be notified of any material received that is not acceptable.
8. Such material will be held for five working days from notification, pending instructions. If a reply is not received within five days, the material will be returned to the sender at his expense.
9. Credit on returned parts will be issued at dealer net price at time of the original purchase, less a 15% restocking charge.
10. In cases where an item is accepted, for which the original purchase document can not be determined, the price will be based on the list price that was effective twelve months prior to the RMA date.
11. Credit issued will be applied to future purchases only.

**PRICING AND REBATES**

Prices are subject to change without prior notice. Price changes are effective on a specific date and all orders received on or after that date will be billed at the revised price. Rebates for price declines and added charges for price increases will not be made for stock on hand at the time of any price change.

Multiquip reserves the right to quote and sell direct to Government agencies, and to Original Equipment Manufacturer accounts who use our products as integral parts of their own products.

**SPECIAL EXPEDITING SERVICE**

A \$35.00 surcharge will be added to the invoice for special handling including bus shipments, insured parcel post or in cases where Multiquip must personally deliver the parts to the carrier.

**LIMITATIONS OF SELLER'S LIABILITY**

Multiquip shall not be liable hereunder for damages in excess of the purchase price of the item with respect to which damages are claimed, and in no event shall Multiquip be liable for loss of profit or good will or for any other special, consequential or incidental damages.

**LIMITATION OF WARRANTIES**

No warranties, express or implied, are made in connection with the sale of parts or trade accessories nor as to any engine not manufactured by Multiquip. Such warranties made in connection with the sale of new, complete units are made exclusively by a statement of warranty packaged with such units, and Multiquip neither assumes nor authorizes any person to assume for it any other obligation or liability whatever in connection with the sale of its products. Apart from such written statement of warranty, there are no warranties, express, implied or statutory, which extend beyond the description of the products on the face hereof.



# PARTS MANUAL

## HERE'S HOW TO GET HELP

PLEASE HAVE THE MODEL AND SERIAL  
NUMBER *ON-HAND* WHEN CALLING

### UNITED STATES

#### ***Multiquip Corporate Office***

18910 Wilmington Ave. Tel. (800) 421-1244  
Carson, CA 90746 Fax (800) 537-3927  
Contact: mq@multiquip.com

#### ***Mayco Parts***

800-306-2926 Fax: 800-672-7877  
310-537-3700 Fax: 310-637-3284

#### ***Service Department***

800-421-1244 Fax: 310-537-4259  
310-537-3700

#### ***MQ Parts Department***

800-427-1244 Fax: 800-672-7877  
310-537-3700 Fax: 310-637-3284

#### ***Warranty Department***

800-421-1244, Ext. 279 Fax: 310-537-1173  
310-537-3700, Ext. 279

#### ***Technical Assistance***

800-478-1244 Fax: 310-631-5032

### MEXICO

#### ***MQ Cipsa***

Carr. Fed. Mexico-Puebla KM 126.5 Tel: (52) 222-225-9900  
Momoxpan, Cholula, Puebla 72760 Mexico Fax: (52) 222-285-0420  
Contact: pmastretta@cipsa.com.mx

### CANADA

#### ***Multiquip***

4110 Industriel Boul. Tel: (450) 625-2244  
Laval, Quebec, Canada H7L 6V3 Fax: (450) 625-8664  
Contact: jmartin@multiquip.com

### UNITED KINGDOM

#### ***Multiquip (UK) Limited Head Office***

Hanover Mill, Fitzroy Street, Tel: 0161 339 2223  
Ashton-under-Lyne, Fax: 0161 339 3226  
Lancashire OL7 0TL  
Contact: sales@multiquip.co.uk

### BRAZIL

#### ***Multiquip***

Av. Evandro Lins e Silva, 840 - grupo 505 Tel: 011-55-21-3433-9055  
Barra de Tijuca - Rio de Janeiro Fax: 011-55-21-3433-9055  
Contact: cnavarro@multiquip.com.br, srentes@multiquip.com.br

© COPYRIGHT 2006, MULTIQIP INC.

Multiquip Inc, the MQ logo are registered trademarks of Multiquip Inc. and may not be used, reproduced, or altered without written permission. All other trademarks are the property of their respective owners and used with permission.

This manual MUST accompany the equipment at all times. This manual is considered a permanent part of the equipment and should remain with the unit if resold.

The information and specifications included in this publication were in effect at the time of approval for printing. Illustrations are based on the *JIMMY Series Hydraulic Rebar Bender*. Illustrations, descriptions, references and technical data contained in this manual are for guidance only and may not be considered as binding. Multiquip Inc. reserves the right to discontinue or change specifications, design or the information published in this publication at any time without notice and without incurring any obligations.

Your Local Dealer is:

