

Genie®



Parts & Service Manual

Refer to inside cover for serial number information

Part No. 80170

Rev B3

December 2005

Superlift™ Advantage

(after serial number SLA04-25258)

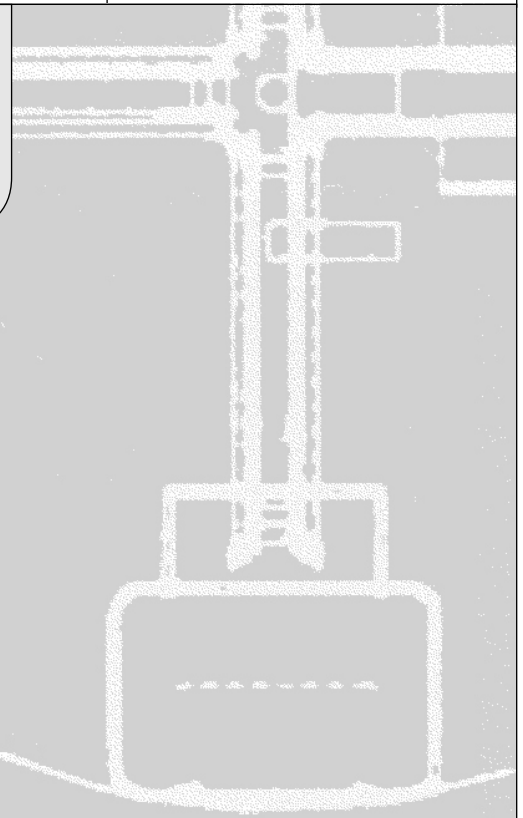

Technical Publications

Genie Industries has endeavored to deliver the highest degree of accuracy possible. However, continuous improvement of our products is a Genie policy. Therefore, product specifications are subject to change without notice.

Readers are encouraged to notify Genie of errors and send in suggestions for improvement. All communications will be carefully considered for future printings of this and all other manuals.

Serial Number Information

Genie Industries offers the following Service Manuals for these models:

Title	Part No.
Genie Superlift Advantage Parts and Service Manual, First Edition (before July 2001)	32283
Genie Superlift Advantage Parts and Service Manual, Second Edition (after June 2001)	80170

Contact Us:

www.genieindustries.com
e-mail: techsup@genieind.com

Copyright © 1994 by Genie Industries

80170 Rev B October 2004
Second Edition, Second Printing

"Genie" is a registered trademark of Genie Industries in the USA and many other countries.
"SLA" is a trademark of Genie Industries.

 Printed on recycled paper

Printed in U.S.A.

How To Read Your Serial Number



Model: GS-1930
Serial number: GS3005A-12345
Model year: 2005 **Manufacture date:** 04/12/05
Electrical schematic number: ES0141
Machine unladen weight: 2,714 lb / 1,231 kg

Rated work load (including occupants): 500 lb / 227 kg

Maximum allowable inclination of the chassis:

N/A

Gradeability: N/A

Maximum allowable side force : 100 lb / 445 kg

Maximum number of platform occupants: 2

Country of manufacture: USA

This machine complies with:

ANSI A92.6-1999
B354.2-01

Genie Industries

18340 NE 76th Street

Redmond, WA 98052

USA

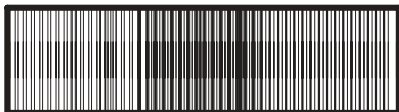

PN - 77055

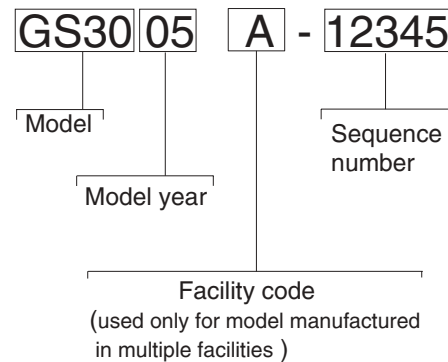

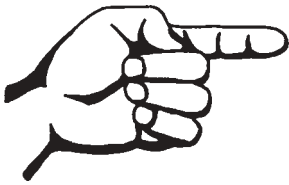

This page intentionally left blank.

Safety Rules



Warning

Failure to obey the instructions and safety rules in this manual and the *Genie Superlift Advantage Operator's Manual* could result in death or serious injury.

Many of the hazards identified in the operating instruction manual are also safety hazards when maintenance and repair procedures are performed.

Do Not Perform Maintenance Unless:

- You are trained and qualified to perform maintenance on this machine.
- You read, understand and obey:
 - manufacturer's instructions and safety rules
 - employer's safety rules and worksite regulations
 - applicable governmental regulations
- You have the appropriate tools, lifting equipment and a suitable workshop.

SAFETY RULES

Personal Safety

Any person working on or around a machine must be aware of all known safety hazards. Personal safety and the continued safe operation of the machine should be your top priority.



Read each procedure thoroughly. This manual and the decals on the machine, use signal words to identify the following:



Safety alert symbol—used to alert personnel to potential personal injury hazards. Obey all safety messages that follow this symbol to avoid possible injury or death.

▲ DANGER

Red—used to indicate the presence of an imminently hazardous situation which, if not avoided, will result in death or serious injury.

▲ WARNING

Orange—used to indicate the presence of a potentially hazardous situation which, if not avoided, could result in death or serious injury.

▲ CAUTION

Yellow with safety alert symbol—used to indicate the presence of a potentially hazardous situation which, if not avoided, may cause minor or moderate injury.

CAUTION

Yellow without safety alert symbol—used to indicate the presence of a potentially hazardous situation which, if not avoided, may result in property damage.

NOTICE

Green—used to indicate operation or maintenance information.



Be sure to wear protective eye wear and other protective clothing if the situation warrants it.



Be aware of potential crushing hazards such as moving parts, free swinging or unsecured components when lifting or placing loads. Always wear approved steel-toed shoes.

Workplace Safety



Be sure to keep sparks, flames and lighted tobacco away from flammable and combustible materials like battery gases and engine fuels. Always have an approved fire extinguisher within easy reach.



Be sure that all tools and working areas are properly maintained and ready for use. Keep work surfaces clean and free of debris that could get into machine components and cause damage.



Be sure that your workshop or work area is properly ventilated and well lit.



Be sure any forklift, overhead crane or other lifting or supporting device is fully capable of supporting and stabilizing the weight to be lifted. Use only chains or straps that are in good condition and of ample capacity.



Be sure that fasteners intended for one time use (i.e., cotter pins and self-locking nuts) are not reused. These components may fail if they are used a second time.



Be sure to properly dispose of old oil or other fluids. Use an approved container. Please be environmentally safe .

Table of Contents

Introduction

Important Information	<i>ii</i>
How To Read Your Serial Number	<i>iii</i>
Recommended Parts Stocking List	<i>xi</i>
How To Order Parts	<i>xii</i>
Service Parts Fax Order Form	<i>xiii</i>

Section 1

Safety Rules

General Safety Rules	<i>v</i>
----------------------------	----------

Section 2

Rev

Specifications

A	SLA-5	2 - 1
A	SLA-10	2 - 1
A	SLA-15	2 - 1
A	SLA-20	2 - 1
A	SLA-25	2 - 1

Section 3

Rev

Scheduled Maintenance Procedures

	Introduction	3 - 1
	Pre-delivery Preparation Report	3 - 3
	Maintenance Inspection Report	3 - 5
B	Checklist A Procedures	
	A-1 Perform Pre-operation Inspection	3 - 6
	A-2 Perform Function Tests	3 - 6
B	Checklist B Procedures	
	B-1 Inspect all Welds	3 - 7
	B-2 Clean the Columns	3 - 7
	B-3 Check the Winch Operation	3 - 8
	B-4 Inspect and Lubricate the Winch	3 - 8
	B-5 Inspect the Carriage Hold-down Bar	3 - 10

 TABLE OF CONTENTS

Section 3	Rev	Scheduled Maintenance Procedures, continued	
	B	Checklist C Procedures	
		C-1 Lubricate the Casters and Wheels	3 - 11
		C-2 Inspect the Mast Assembly for Wear	3 - 11
		C-3 Replace the Winch Friction Discs	3 - 13
		C-4 Inspect the Safety Brake System (if equipped)	3 - 13
		C-5 Inspect the Painted Surfaces	3 - 15
<hr/>			
Section 4	Rev	Troubleshooting Flow Charts	
		Introduction	4 - 1
	B	Chart 1: Mast Will Not Sequence Properly	4 - 2
	B	Chart 2: Carriage Will Not Raise, But Winch Will Operate	4 - 3
	B	Chart 3: Winch Will Not Operate	4 - 4
<hr/>			
Section 5	Rev	Repair Procedures	
		Introduction	5 - 1
	B	1-1 Base	5 - 2
		2-1 Mast Assembly	5 - 3
		2-2 Lifting Cable	5 - 7
		2-3 Lifting Pulley	5 - 8
		3-1 One-speed Winch	5 - 10
		3-2 Two-speed Winch	5 - 13

TABLE OF CONTENTS

Section 6	Rev	Decals and Paint	
Figure 6-A	B	Decals	6 - 2
Figure 6-B	B	Decals with Words	6 - 4
Figure 6-C	B	Decals with Symbols	6 - 6
Section 7	Rev	Base Components	
Figure 7-A	B	Base Components, Standard	7 - 2
Figure 7-B	B	Base Components, Straddle (SLA-5, SLA-10 and SLA-15)	7 - 6
Figure 7-C	C	Base Components, All Models	7 - 8
Section 8	Rev	Mast and Winch Components	
Figure 8-A	B	Mast Components, View 1	8 - 2
Figure 8-B	B	Mast Components, View 2	8 - 4
Figure 8-C	C	Mast Components, View 3	8 - 6
Figure 8-D	C	Columns, Pulleys and Cables	8 - 10
Figure 8-E	C	Winch Components, One-speed	8 - 14
Figure 8-F	C	Winch Components, Two-speed	8 - 16
Section 9	Rev	Accessories	
Figure 9-A	B	Forks	9 - 2
Figure 9-B	B	Pipe Cradle, Load Platform and Boom Arm	9 - 4
Figure 9-C	B	Rear Wheels	9 - 6

Parts Stocking List

Recommended Parts

Description	Part No.
Genie Gray Paint, 12 Ounce / 355 ml Aerosol	1268
Genie Blue Paint, 12 Ounce / 355 ml Aerosol	1484
Genie Blue Paint, 1 Gallon / 3.78 liters	32150
Genie Gray Paint, 1 Gallon / 3.78 liters	32151
Pinion Plate (One-speed Winch)	7591
Pinion Plate (Two-speed Winch)	40122
Ratchet Gear (One-speed Winch)	6777
Ratchet Gear (Two-speed Winch)	40121
Pinion Gear (One-speed Winch)	7590
Pinion Gear (Two-speed Winch)	80157
Pinion Shaft (One-speed Winch)	32891
Ratchet Pawl Kit (One-speed Winch)	40458
Ratchet Pawl Kit (Two-speed Winch)	40117
Cable Keeper Kit (One-speed Winch)	6190
Primary Shaft Assembly	72264
Cable Assembly (SLA-5 models)	35143
Cable Assembly (SLA-10 models)	35144
Cable Assembly (SLA-15 models)	35145
Cable Assembly (SLA-20 models)	35146
Pin Assembly with Lanyard	32940
Roller Bolt, 1/2-13 x 1.84 inches	32475
Nylatron Roller, 1.75 x 0.72 inch	32473
Safety Brake Assembly	35101
Safety Brake Tool Assembly	33875
Loctite Thread Lock	65764
Genie Superlift Cabling Procedure Video	52701

Required Parts

The following parts are required to perform maintenance procedures as outlined in the *Genie Superlift Advantage Parts and Service Manual*.

Description	Part No.
White Lithium Grease	91670
Cable Replacement Coupler	12402
Disc Brake (One-speed Winch)	7571
Disc Brake (Two-speed Winch)	80157

Manuals

Genie Industries offers the following support documents for these models:

Title	Part No.
Genie Superlift Advantage Operator's Manual (before January 2004)	33499
Genie Superlift Advantage Operator's Manual (after December 2004)	97550
Genie Superlift Advantage Parts and Service Manual (before July 2001)	32283
Genie Superlift Advantage Parts and Service Manual (after June 2001)	80170
EMI Safety Manual	27581

How To Order Parts

Please be prepared with the following information when ordering replacement parts for your Genie product:

- Machine model number
- Machine serial number
- Genie part number
- Part description and quantity
- Purchase order number
- "Ship to" address
- Desired method of shipment
- Name and telephone number of the authorized Genie Distributor in your area

Use the Service Parts Fax Order Form on the next page and fax your order to our Parts Department.

If you don't know the name of your authorized distributor, or if your area is not currently serviced by an authorized distributor, please call Genie Industries.

Machine Information

Model

Serial Number

Date of Purchase

Authorized Genie Distributor

Phone Number

Genie North America

Telephone (425) 556-6551

Toll Free (877) 367-5606 in U.S.A. and Canada

Fax (425) 556-8659

Genie UK

Parts Telephone (44) (0) 1476 584352

Parts Fax (44) (0) 1476 584340

Genie Australia

Parts Telephone (617) 03375 1660

Parts Fax (617) 03375 1002

Genie France

Parts Telephone (33) (0) 237 26 09 99

Parts Fax (33) (0) 237 31 50 10

Genie Germany

Parts Telephone (49) (0) 4202 885223

Parts Fax (49) (0) 4202 885225

Genie Scandinavia

Parts Telephone (46) (31) 3409612

Parts Fax (46) (31) 3409613

Genie Iberica

Parts Telephone (34) (93) 5795042

Genie Brazil

Parts Telephone (55) (114) 1665755

Parts Fax (55) (114) 1665754

Genie Japan

Parts Telephone (81) (33) 4536082

Parts Fax (81) (33) 4536083

Genie China

Parts Telephone (86) (215) 3852570

Parts Fax (86) (215) 3852569

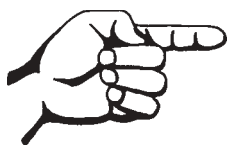

This page intentionally left blank.

REV A

Specifications

Model	SLA-5	SLA-10	SLA-15	SLA-20	SLA-25
Height - Stowed	78 ¹ / ₂ in 2 m	78 ¹ / ₂ in 2 m	78 ¹ / ₂ in 2 m	78 ¹ / ₂ in 2 m	78 ¹ / ₂ in 2 m
Width Standard Base	31 ¹ / ₂ in 80 cm	31 ¹ / ₂ in 80 cm	31 ¹ / ₂ in 80 cm	31 ¹ / ₂ in 80 cm	31 ¹ / ₂ in 80 cm
Width - stabilizers lowered Standard Base	78 ⁵ / ₈ in 2 m	78 ⁵ / ₈ in 2 m	78 ⁵ / ₈ in 2 m	78 ⁵ / ₈ in 2 m	78 ⁵ / ₈ in 2 m
Width - Minimum Straddle Base	31 ¹ / ₂ in 80 cm	31 ¹ / ₂ in 80 cm	31 ¹ / ₂ in 80 cm	NA	NA
Width - Maximum Straddle Base	58 in 1.5 m	58 in 1.5 m	58 in 1.5 m	NA	NA
Length - Stowed	29 in 74 cm	29 in 74 cm	29 in 74 cm	29 in 74 cm	31 in 79 cm
Length - Operating	59 ¹ / ₂ in 1.5 m	59 ¹ / ₂ in 1.5 m	72 ¹ / ₂ in 184 cm	80 ¹ / ₂ in 204 cm	80 ¹ / ₂ in 204 cm
Ground Clearance	2 in 50.8 mm	2 in 50.8 mm	2 in 50.8 mm	2 in 50.8 mm	2 in 50.8 mm
Load Capacity at 18 inch / 46 cm load center	1000 lbs 454 kg	1000 lbs 454 kg	800 lbs 363 kg	800 lbs 363 kg	650 lbs 295 kg
Net Weight - Standard Base	215 lbs 97.5 kg	260 lbs 117.9 kg	317 lbs 143.8 kg	405 lbs 183.7 kg	450 lbs 204.1 kg
Net Weight - Straddle Base	258 lbs 117.0 kg	303 lbs 137.4 kg	360 lbs 163.3 kg	NA	NA
Load Handling Attachments	Length	Width	Depth	Net Weight	
Standard Forks	27 ¹ / ₂ in 70 cm	23 ¹ / ₂ in 60 cm	2 ¹ / ₂ in 6.4 cm	38 lbs 17.2 kg	
Adjustable Forks	27 ¹ / ₂ in 70 cm	11 ¹ / ₂ in to 30 in 29 cm to 76 cm	2 ¹ / ₂ in 6.4 cm	52.5 lbs 23.8 kg	
Flat Forks	32 in 81 cm	16 in to 31 in 41 cm to 79 cm	1 ¹ / ₂ in 3.8 cm	73 lbs 33.1 kg	
Boom	18 in to 42 in 46 cm to 1.1 m	1 ¹ / ₂ in 4 cm	6 ¹ / ₂ in 16.5 cm	34.5 lbs 15.6 kg	
Vertical Barrel Stacker	21 in 53 cm	29 in 74 cm	NA	50.5 lbs 22.9 kg	
Rotating Barrel Handler	29 in 74 cm	31 in 79 cm	NA	90 lbs 40.8 kg	
Pipe Cradle	27 ¹ / ₂ in 70 cm	24 ¹ / ₂ in 63 cm	6 in 15.2 cm	10 lbs 4.5 kg	
Load Platform	27 ¹ / ₂ in 70 cm	23 ¹ / ₂ in 60 cm	2 ¹ / ₂ in 6.4 cm	26.5 lbs 12 kg	
Fork extensions (each)	30 in 76 cm	2 in 5 cm	3 in 7.6 cm	4.5 lbs 2 kg	

SPECIFICATIONS

REV A

Dimensions		SLA-5	SLA-10	SLA-15	SLA-20	SLA-25
Standard Forks	Forks Down	4 ft 10 ¹ / ₂ in 1.5 m	9 ft 9 in 3 m	14 ft 7 ¹ / ₂ in 4.5 m	19 ft 6 in 5.9 m	24 ft 4 in 7.4 m
	Forks Up	6 ft 7 in 2 m	11 ft 5 ¹ / ₂ in 3.5 m	16 ft 4 in 5 m	21 ft 2 ¹ / ₂ in 6.5 m	26 ft 1 ¹ / ₂ in 7.9 m
Adjustable Forks	Forks Down	4 ft 10 ¹ / ₂ in 1.5 m	9 ft 9 in 3 m	14 ft 7 ¹ / ₂ in 4.5 m	19 ft 6 in 6 m	24 ft 4 in 7.4 m
	Forks Up	6 ft 7 in 2 m	11 ft 5 ¹ / ₂ in 3.5 m	16 ft 4 in 5 m	21 ft 2 ¹ / ₂ in 6.5 m	26 ft 1 ¹ / ₂ in 7.9 m
Flat Forks		4 ft 10 ¹ / ₂ in 1.5 m	9 ft 9 in 3 m	14 ft 7 ¹ / ₂ in 4.5 m	NA	NA
Boom		5 ft 10 ¹ / ₂ in 1.8 m	10 ft 9 in 3.3 m	15 ft 7 ¹ / ₂ in 4.8 m	20 ft 6 in 6.2 m	24 ft 4 in 7.4 m
Note: measured from ground to bottom of shackle						
Vertical Barrel Stacker	30 gallon	4 ft 1.2 m	8 ft 10 in 2.7 m	13 ft 9 in 4.2 m	NA	NA
	55 gallon	3 ft 10 in 1.2 m	8 ft 8 in 2.6 m	13 ft 7 in 4.1 m		
Note: measured from ground to bottom of barrel						
Rotating Barrel Handler	55 gallon	3 ft 10 in 1.2 m	8 ft 8 in 2.6 m	13 ft 7 in 4.1 m	NA	NA
	30 gallon	3 ft 10 in 1.2 m	8 ft 8 in 2.6 m	13 ft 7 in 4.1 m	NA	NA
Note: measured from ground to bottom of barrel						
Load Platform	forks down	4 ft 10 ¹ / ₂ in 1.5 m	9 ft 9 in 3 m	14 ft 7 ¹ / ₂ in 4.5 m	19 ft 6 in 6 m	24 ft 4 in 7.4 m
	forks up	6 ft 7 in 2 m	11 ft 5 ¹ / ₂ in 3.5 m	16 ft 4 in 5 m	21 ft 2 ¹ / ₂ in 6.5 m	26 ft 1 ¹ / ₂ in 7.9 m
Note: can be used with standard forks and adjustable forks only						
Pipe Cradle Option	handles round objects up to 30 in / 76 cm in diameter					
Note: can be used with standard forks and adjustable forks only (see above for working heights)						
Non-marking Fork Option						
Note: can be used with standard forks and adjustable forks only (see above for working heights)						
Fork Extension Option	adds 6 ¹ / ₄ to 25 inches / 15 to 64 cm of length to forks					
Note: can be used with standard forks and adjustable forks only (see above for working heights)						
Airborne Noise Emissions by Machinery	85 dB	85 dB	85 dB	85 dB	85 dB	85 dB
Maximum sound level at normal operating workstations (A-weighted)						

Scheduled Maintenance Procedures



Observe and Obey:

- ☑ Maintenance procedures shall be completed by a person trained and qualified on the maintenance of this machine.
- ☑ Scheduled maintenance procedures shall be completed daily, quarterly and annually as specified on the maintenance inspection report.

⚠ WARNING Failure to properly complete each inspection when required could result in death, serious injury or substantial machine damage.

- ☑ Immediately tag and remove from service a damaged or malfunctioning machine.
- ☑ Repair any machine damage or malfunction before operating machine.
- ☑ Keep records on all inspections for three years.
- ☑ Be sure the capacities of sawhorses or other supports are sufficient to withstand machine weight. See Specifications section for the machine weight.
- ☑ Be sure overhead cranes or other lifting devices are of ample capacity to handle machine weight. See Specifications section for machine weight.
- ☑ Unless otherwise specified, perform each procedure with the machine in the following configuration:
 - Machine positioned on a firm, level surface
 - Carriage fully lowered
 - Casters locked
 - Load handling attachment installed

About This Section

This section contains detailed procedures for each scheduled maintenance inspection.

Each procedure includes a description, safety warnings and step-by-step instructions.

Symbols Legend



Safety alert symbol—used to alert personnel to potential personal injury hazards. Obey all safety messages that follow this symbol to avoid possible injury or death.

⚠ DANGER

Red—used to indicate the presence of an imminently hazardous situation which, if not avoided, will result in death or serious injury.

⚠ WARNING

Orange—used to indicate the presence of a potentially hazardous situation which, if not avoided, could result in death or serious injury.

⚠ CAUTION

Yellow with safety alert symbol—used to indicate the presence of a potentially hazardous situation which, if not avoided, may cause minor or moderate injury.

CAUTION

Yellow without safety alert symbol—used to indicate the presence of a potentially hazardous situation which, if not avoided, may result in property damage.

NOTICE

Green—used to indicate operation or maintenance information.

- ⦿ Indicates that a specific result is expected after performing a series of steps.

SCHEDULED MAINTENANCE PROCEDURES

REV A

Maintenance Symbols Legend**NOTICE**

The following symbols have been used in this manual to help communicate the intent of the instructions. When one or more of the symbols appear at the beginning of a maintenance procedure, it conveys the meaning below.



Indicates that tools will be required to perform this procedure.



Indicates that new parts will be required to perform this procedure.



Indicates that dealer service will be required to perform this procedure.

Pre-delivery Preparation Report

The pre-delivery preparation report contains checklists for each type of scheduled inspection.

Make copies of the *Pre-delivery Preparation Report* to use for each inspection. Store completed forms as required.

Maintenance Schedule

There are three types of maintenance inspections that must be performed according to a schedule—daily, quarterly and annual. The *Scheduled Maintenance Procedures Section* and the *Maintenance Inspection Report* have been divided into three subsections—A, B and C. Use the following chart to determine which group(s) of procedures are required to perform a scheduled inspection.

Inspection	Checklist
Daily or every 8 hours	A
Quarterly or every 250 hours	A + B
Annual or every 1000 hours	A + B + C

Maintenance Inspection Report

The maintenance inspection report contains checklists for each type of scheduled inspection.

Make copies of the *Maintenance Inspection Report* to use for each inspection. Store completed forms for three years.

Pre-Delivery Preparation

It is the responsibility of the dealer to perform the Pre-delivery Preparation.

The Pre-delivery Preparation is performed prior to each delivery. The inspection is designed to discover if anything is apparently wrong with a machine before it is put into service.

A damaged or modified machine must never be used. If damage or any variation from factory delivered condition is discovered, the machine must be tagged and removed from service.

Repairs to the machine may only be made by a qualified service technician, according to the manufacturer's specifications.

Scheduled maintenance inspections shall be performed by qualified service technicians, according to the manufacturer's specifications and the requirements listed in the responsibilities manual.

Use the operator's manual on your machine.

The Pre-delivery Preparation consists of completing the Pre-operation Inspection, the Maintenance items and the Function Tests.

Use this form to record the results. Place a check in the appropriate box after each part is completed. Follow the instructions in the operator's manual.

If any inspection receives an N, remove the machine from service, repair and re-inspect it. After repair, place a check in the R box.

Legend

Y = yes, completed
N = no, unable to complete
R = repaired

Comments

Pre-Delivery Preparation	Y	N	R
Pre-operation inspection completed			
Maintenance items completed			
Function tests completed			

Model

Serial number

Date

Machine owner

Inspected by (print)

Inspector signature

Inspector title

Inspector company



Genie Industries USA
18340 NE 76th Street
PO Box 97030
Redmond, WA 98073-9730
(425) 881-1800

Genie UK
The Maltings, Wharf Road
Grantham, Lincolnshire
NG31-6BH England
(44) 1476-584333



This page intentionally left blank.

Maintenance Inspection Report

Model
Serial number
Date
Machine owner
Inspected by (print)
Inspector signature
Inspector title
Inspector company

Checklist A	Y	N	R
A-1 Pre-operation Inspection			
A-2 Function Tests			

Checklist B	Y	N	R
B-1 Welds			
B-2 Clean columns			
B-3 Winch Operation			
B-4 Inspect and lubricate winch			
B-5 Carriage hold-down bar			

Checklist C	Y	N	R
C-1 Lubricate the casters and wheels			
C-2 Mast assembly wear			
C-3 Replace winch friction disks			
C-4 Safety brake system (if equipped)			
C-5 Painted surfaces			

Instructions

- Make copies of this report to use for each inspection.
- Select the appropriate checklist(s) for the type of inspection to be performed.

	Daily or 8 hour Inspection:	A
	Quarterly or 250 hour Inspection:	A+B
	Annual or 1000 hour Inspection:	A+B+C

- Place a check in the appropriate box after each inspection procedure is completed.
- Use the step-by-step procedures in this section to learn how to perform these inspections.
- If any inspection receives an "N", tag and remove the machine from service, repair and re-inspect it. After repair, place a check in the "R" box.

Legend

- Y = yes, acceptable
- N = no, remove from service
- R = repaired

Comments

Checklist A Procedures

REV B

A-1 Perform Pre-operation Inspection

Completing a Pre-operation Inspection is essential to safe machine operation. The Pre-operation Inspection is a visual inspection performed by the operator prior to each work shift. The inspection is designed to discover if anything is apparently wrong with a machine before the operator performs the function tests. The Pre-operation Inspection also serves to determine if routine maintenance procedures are required.

Complete information to perform this procedure is available in the appropriate operator's manual. Refer to the Operator's Manual on your machine.

A-2 Perform Function Tests

Completing the function tests is essential to safe machine operation. Function tests are designed to discover any malfunctions before the machine is put into service. A malfunctioning machine must never be used. If malfunctions are discovered, the machine must be tagged and removed from service.

Complete information to perform this procedure is available in the appropriate operator's manual. Refer to the Operator's Manual on your machine.

Checklist B Procedures

REV B

B-1 Inspect All Welds

Weld inspections are essential to safe machine operation and good machine performance. Failure to locate and repair damage may result in an unsafe operating condition.

- 1 Visually inspect the welds in the following locations:
 - Winch mounting plate
 - Loading wheels/steer handle
 - Base
 - Legs and stabilizers
 - Load handling attachment(s)

B-2 Clean the Columns



Clean columns are essential to good machine performance and safe operation. Extremely dirty conditions may require that the columns be cleaned more often.

- 1 Raise all columns to full height.
- 2 Visually inspect the inner and outer channels of the columns for debris or foreign material. If necessary, use a mild cleaning solvent to clean the columns.

▲WARNING Bodily injury hazard. This procedure will require the use of additional access equipment. Do not place ladders or scaffold on or against any part of the machine. Performing this procedure without the proper skills and tools could result in death or serious injury. Dealer service is strongly recommended.

CHECKLIST B PROCEDURES

REV B

B-3 Check the Winch Operation

Detection of damage to the winch is essential to safe machine operation. An unsafe working condition exists if the winch is damaged or not operating correctly. A daily check of the winch operation allows the inspector to identify changes in the operating condition of the winch that might indicate damage.

- 1 Visually inspect all the winch components for damage.
- 2 Raise the carriage through a partial cycle and release the winch handles.
 - ⊙ Result: The winch should operate smoothly, free of hesitation or binding. The load should not lower when the handles are released.
- 3 Fully lower the carriage.
 - ⊙ Result: The winch should operate smoothly, free of hesitation or binding.

B-4 Inspect and Lubricate the Winch



Maintaining the winch is essential to good machine performance and safe operation. An unsafe working condition exists if the winch has excessive wear and/or does not operate smoothly, free of hesitation and binding.

- 1 Carefully lubricate the following areas with automotive grease:
 - Cable drum gear
 - Teeth on the pinion gear that mesh with the cable drum gear
 - Threads on the pinion shaft, under the pinion gear
 - **Models with Two-speed winch:** The teeth on the slow and the fast speed gears where they mesh together

NOTICE

Do not apply grease to brake friction disks or ratchet gear.

- 2 Carefully lubricate both pivot points on each ratchet pawl with 30W oil.

REV B

CHECKLIST B PROCEDURES

- 3 Measure each friction disk for wear. Replace the friction disk if it measures less than specification.

Friction disk specification

Thickness, minimum	1/16 inch
	1.5 mm

- 4 Measure both shaft bushings for wear. Replace the bushings if the wall thickness measurements are less than specification.

Pinion shaft bushing specification

Wall thickness, minimum	1/8 inch
	3.1 mm

- 5 Lubricate the surface of the frame drum spacer with a thin layer of lithium grease. Tighten the drum bolt to 20 ft-lbs / 27 Nm. Do not overtighten.

CHECKLIST B PROCEDURES

REV B

B-5
Inspect the
Carriage Hold-down Bar

Detection of damage to the column hold down system is essential for safe machine operation. An unsafe working condition exists if the system is damaged and does not operate properly.

- 1 Using proper lifting techniques, lay the machine back against a sawhorse or other suitable support.
- 2 Visually inspect the carriage hold-down bar for damage
- 3 Check the carriage hold-down bar for smooth operation.

Checklist C Procedures

REV B

C-1 Lubricate the Casters and Wheels



Regular application of lubrication to the Caster or Wheel is essential to good machine performance and service life. Extremely dirty conditions may require that the casters and wheels be inspected and lubricated more often.

- 1 Visually inspect each caster and wheel for cuts, cracks or unusual wear.
- 2 Move the machine on a flat smooth surface and check that the casters and wheels roll smoothly, free of hesitation and binding.
- 3 Pump grease into the caster or wheel until it can be seen coming out of the bearing gap.

Grease Type	Lithium-based
--------------------	---------------

C-2 Inspect the Mast Assembly for Wear



Detection of excessive or unusual wear in the mast assembly is essential for safe machine operation. An unsafe working condition exists if the mast assembly has excessive wear and/or does not operate smoothly, free of hesitation and binding.

- 1 Attach a lifting strap from an overhead crane or similar lifting device to the lifting point on the top of the mast. Rotate the carriage hold-down bar over the carriage and operate the winch to apply tension to the lifting cable.
- 2 Lift the machine slightly with the overhead crane and guide it onto a suitable structure capable of supporting it.

WARNING Crushing hazard. The machine will fall if not properly supported by the overhead crane.

- 3 Lower the top of the mast onto the suitable structure.
- 4 Attach a lifting strap from an overhead crane to the base of the machine.
- 5 Lift the base with the overhead crane, until the mast is level and place another suitable structure under the mast.

CHECKLIST C PROCEDURES

REV B

- 6 Lower the base end of the machine.
- 7 Rotate the mast assembly until the carriage is on top.



- 9 Visually inspect the bottom of each column for clearance between the roller wheel and the adjacent column surface.
- ⊙ Result: There should be a gap of less than 0.062 inch / 1.57 mm between the roller wheel and the column.

NOTICE

If the mast inspection results in a measurement that is not within specification, refer to Repair procedure 2-1, *How to Disassemble the Mast Assembly*.

- 8 Visually inspect the top of each column for clearance between the roller wheel and the adjacent column surface.
- ⊙ Result: There should be a gap of less than 0.062 inch / 1.57 mm between the roller wheel and the column.

NOTICE

If the mast inspection results in a measurement that is not within specification, See Repair procedure 2-1, *How to Disassemble the Mast Assembly*.

REV B

CHECKLIST C PROCEDURES

C-3

Replace the Winch Friction Disks



Maintaining the winch is essential to good machine performance and safe operation. An unsafe working condition exists if the winch has excessive wear and/or does not operate smoothly, free of hesitation and binding.

- 1 Replace the winch friction disks. See Repair procedure 3-1 *How to Disassemble a One-speed Winch*, or 3-2, *How to Disassemble a Two-speed Winch*.

C-4

Inspect the Safety Brake System (if equipped)



Detection of damage or a faulty safety brake system is essential for safe machine operation. An unsafe working condition exists if the system is damaged or faulty and does not allow the mast to sequence properly, free of hesitation and binding.

▲WARNING Bodily injury hazard. This procedure requires specific repair skills and a suitable workshop. Attempting this procedure without these skills could result in death or serious injury or significant component damage. Dealer service is strongly recommended.

▲CAUTION Bodily injury hazard. Beware of sharp edges. Wear protective gloves when performing this procedure.

- 1 Fasten a load handling attachment to the carriage (use the forks or the boom if possible). Do not place any weight on the load handling attachment.
- 2 Raise the carriage until it is half way up the front column
- 3 Grasp the bottom carriage and lift it approximately 12 inches / 30 cm, then release the carriage.

CHECKLIST C PROCEDURES

REV B

- ⦿ Result: The carriage should stop within 5 to 8 inches / 12.7 to 20.3 cm and the safety brake should engage.

CAUTION Crushing hazard. Do not stand directly under the carriage or load handling attachment.

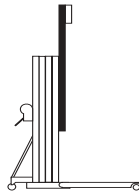

- 4 Raise the carriage approximately 12 inches / 30.5 cm to disengage the safety brake.
- 5 Operate the winch until the front column is half way up the adjacent column.
- 6 Grasp the bottom of the front column and lift it approximately 5 inches / 12 cm, then release the column.

- ⦿ Result: The carriage should stop within 5 to 8 inches / 12 to 20 cm and the safety brake should engage.

CAUTION Crushing hazard. Do not stand directly under the columns or load handling attachment.

- 7 Raise the front column approximately 12 inches / 30 cm to disengage the safety brake.
- 8 Operate the winch until the front column is fully raised and the second column is half way up the adjacent column.
- 9 Grasp the bottom side of the next column and lift it approximately 12 inches / 30 cm, then release the column.
- ⦿ Result: The carriage should stop within 5 to 8 inches / 12 to 20 cm and the safety brake should engage.

CAUTION Crushing hazard. Do not stand directly under the columns or load handling attachment.

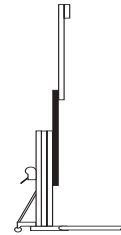

- 10 Repeat steps 7 through 9 to test all remaining columns.

NOTICE When disengaging the safety brake, it may be necessary to hold down the column behind the column to be disengaged.

NOTICE The number one column (column attached to the base) does not have a safety brake and will not need to be tested.

REV B

CHECKLIST C PROCEDURES

C-5

Inspect the Painted Surfaces

Inspecting the painted surfaces of your machine is essential to safe operation and long machine life. An unsafe working condition exists if there is damage to painted surfaces that is not corrected.

- 1 Visually inspect all painted surfaces for the following conditions:
 - Blistering
 - Rust
 - Peeling
 - Fading
 - Corrosion

NOTICE Replace any component that is damaged.



This page intentionally left blank.

Troubleshooting Flow Charts



Observe and Obey:

- ☑ Troubleshooting and repair procedures shall be completed by a person trained and qualified on the repair of this machine.
- ☑ Immediately tag and remove from service a damaged or malfunctioning machine.
- ☑ Repair any machine damage or malfunction before operating the machine.
- ☑ Be sure the capacities of sawhorses or other supports are sufficient to withstand machine weight. See Specifications section for specific weight.
- ☑ Be sure overhead cranes or other lifting devices are of ample capacity to handle machine weight. See Specification section for specific weight.

Before Troubleshooting:

- ☑ Read, understand and obey the safety rules and operating instructions printed in the *Genie Superlift Advantage Operator's Manual*.
- ☑ Be sure that all necessary tools and test equipment are available and ready for use.
- ☑ Read each appropriate flow chart thoroughly. Attempting shortcuts may produce hazardous conditions.
- ☑ Be aware of the following hazards and follow generally accepted safe workshop practices.

⚠ DANGER Crushing hazard. When testing or replacing the primary component, always support the structure and secure it from movement.

NOTICE Perform all troubleshooting on a firm, level surface.

NOTICE Two people will be required to safely perform some troubleshooting procedures.

About This Section

When a malfunction is discovered, the flow charts in this section will help a service professional pinpoint the cause of the problem. To use this section, basic hand tools are required.

General Repair Process

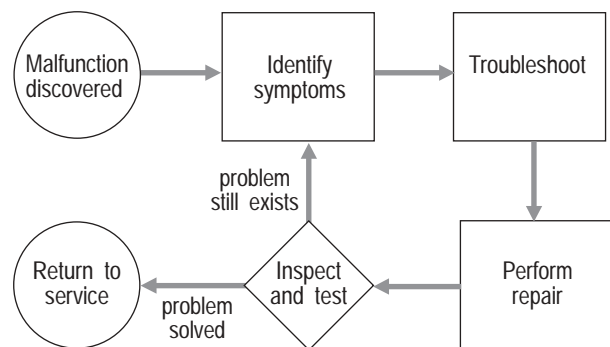

Chart 1

REV A

Mast Will Not Sequence Properly

Be sure safety brake (if equipped) is not engaged by fully raising and lowering all columns.

Improper sequencing of the mast columns may occur when the machine is at or near maximum capacity. If improper sequencing occurs, the columns may shift to their correct position during operation or when the load is removed. The forks will not change position if the columns shift position. The carriage should always raise first, and lower last.

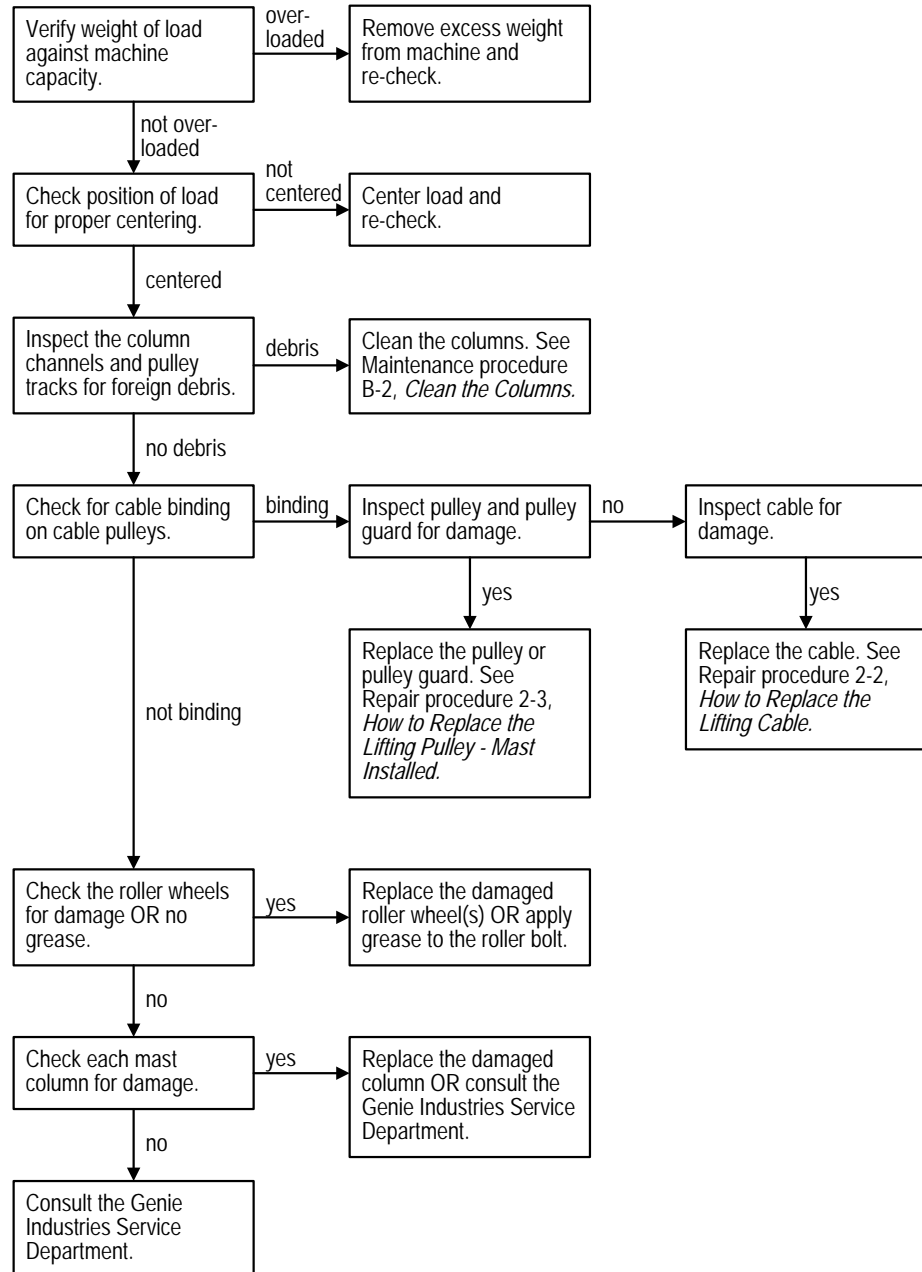

Chart 2

REV A

Carriage Will Not Raise, But Winch Will Operate

Be sure the carriage hold-down bar is not engaged.

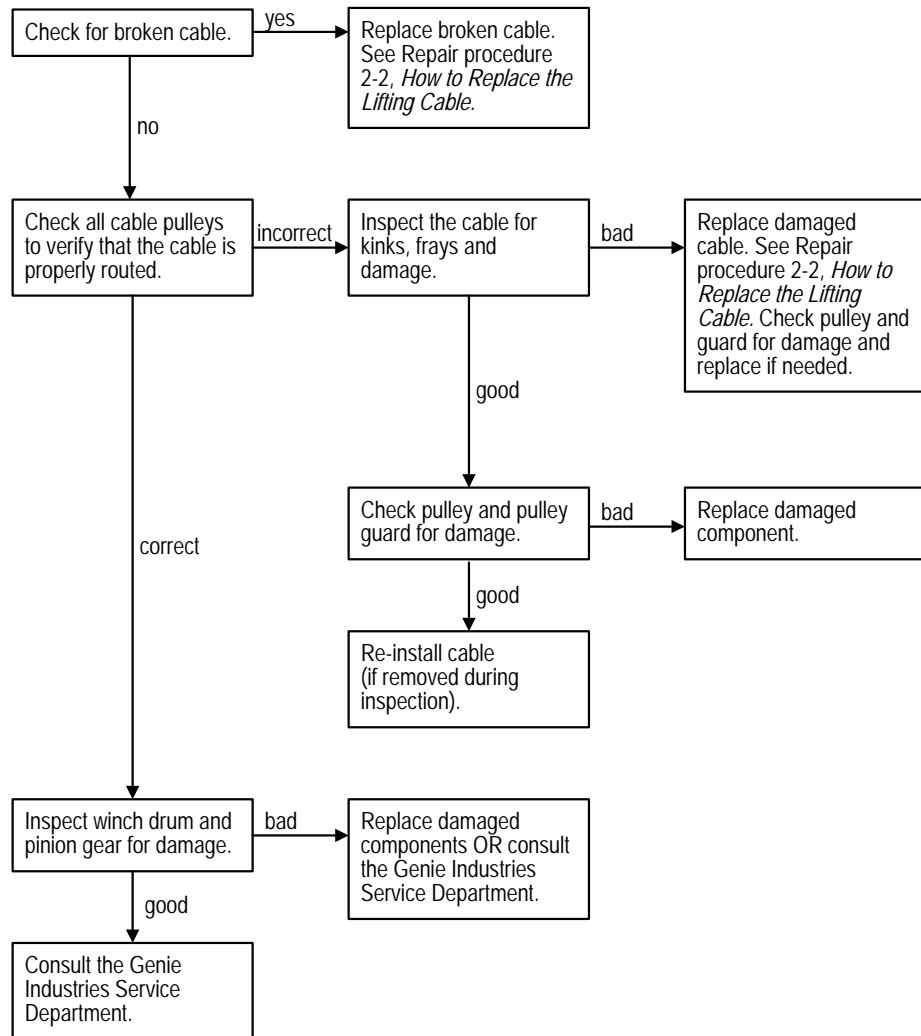
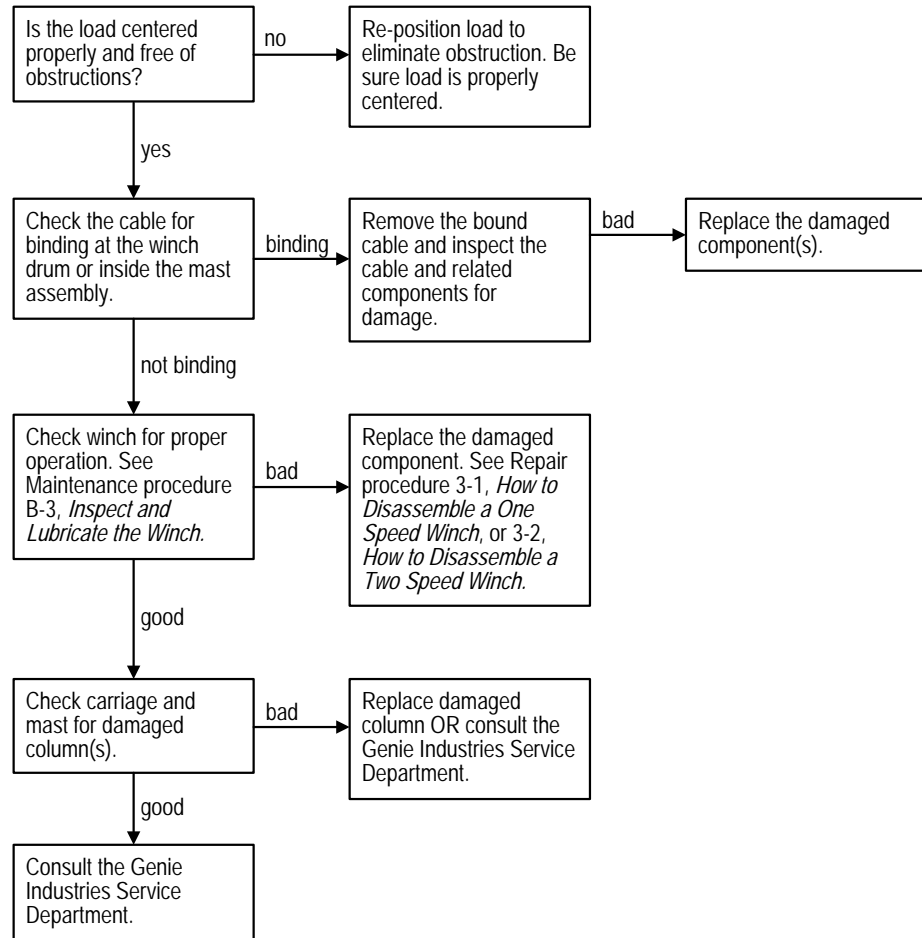

Chart 3

REV A

Winch Will Not Operate



Repair Procedures



Observe and Obey:

- ☑ Repair procedures shall be completed by a person trained and qualified on the repair of this machine.
- ☑ Immediately tag and remove from service a damaged or malfunctioning machine.
- ☑ Repair any machine damage or malfunction before operating the machine.

Before Repairs Start:

- ☑ Read, understand and obey the safety rules and operating instructions in the *Genie Superlift Advantage Operator's Manual*.
- ☑ Be sure that all necessary tools and parts are available and ready for use.
- ☑ Be sure the capacities of sawhorses or other supports are sufficient to withstand machine weight. See Specifications section for the machine weight.
- ☑ Be sure overhead cranes or other lifting devices are of ample capacity to handle machine weight. See Specifications section for specific weight.
- ☑ Read each procedure completely and adhere to the instructions. Attempting shortcuts may produce hazardous conditions.
- ☑ Unless otherwise specified, perform each procedure with the machine in the following configuration:
 - Machine positioned on a firm, level surface
 - Carriage fully lowered
 - Casters locked

About This Section

Most of the procedures in this section should only be performed by a trained service professional in a suitably equipped workshop. Select the appropriate repair procedure after troubleshooting the problem.

Perform disassembly procedures to the point where repairs can be completed. To re-assemble, perform the disassembly steps in reverse order.

Symbols Legend



Safety alert symbol—used to alert personnel to potential personal injury hazards. Obey all safety messages that follow this symbol to avoid possible injury or death.

▲ DANGER

Red—used to indicate the presence of an imminently hazardous situation which, if not avoided, will result in death or serious injury.

▲ WARNING

Orange—used to indicate the presence of a potentially hazardous situation which, if not avoided, could result in death or serious injury.

▲ CAUTION

Yellow with safety alert symbol—used to indicate the presence of a potentially hazardous situation which, if not avoided, may cause minor or moderate injury.

CAUTION

Yellow without safety alert symbol—used to indicate the presence of a potentially hazardous situation which, if not avoided, may result in property damage.

NOTICE

Green—used to indicate operation or maintenance information.

- ⦿ Indicates that a specific result is expected after performing a series of steps.

Base Assembly

REV A

1-1 Base

How to Remove the Base

- 1 Loosen the locking screw and retract the extendable legs (if equipped).
- 2 Fully lower the carriage.
- 3 Remove the load handling attachment from the machine.

Models with stabilizers:

- 4 Remove the mounting fasteners from the stabilizer mounting bracket on the back of the mast.
- 5 Remove the mounting fastener from each stabilizer at the base. Remove each stabilizer from the machine.

All Models:

- 6 Using proper lifting techniques, tilt the machine back and rest the loading wheels against a suitable structure capable of supporting it.

CAUTION Bodily injury hazard. Use proper lifting techniques when rolling the mast assembly over.



- 7 Remove the mounting fastener and retaining pin from each leg. Remove the legs from the machine.
- 8 Using proper lifting techniques, carefully tilt the machine to the upright position.

CAUTION Bodily injury hazard. Use proper lifting techniques when tilting the machine to the upright position.

- 9 Attach a lifting strap from an overhead crane to the lifting eye at the top of the number one mast column.
- 10 Position a suitable structure capable of supporting the machine on the carriage side of the mast.
- 11 Carefully lift the machine slightly with the overhead crane. While lowering it, guide the machine over onto a suitable structure capable of supporting it.

CAUTION Crushing hazard. The machine may become unbalanced and fall if not properly supported by the overhead crane.

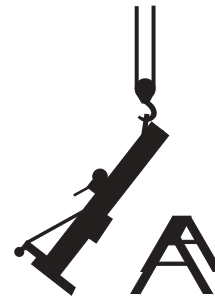

REV A

Mast Assembly

- 12 Secure the top of the mast to the support.
- 13 Attach a lifting strap from an overhead crane to the base and lift the machine to a horizontal position. Slide a second suitable structure capable of supporting it under the mast, next to the base.

▲WARNING Crushing hazard. The machine could become unbalanced and fall if not properly supported by the overhead crane.

- 14 Remove the mounting fasteners from both mast braces at the base.
- 15 Remove the base mounting fasteners. Remove the base from the machine.

NOTICE When installing the base, be sure that the mast and the base are square.

2-1 Mast Assembly

How to Disassemble the Mast Assembly

NOTICE Removal of the base is only necessary when the number one column is to be removed. See 1-1, *How to Remove the Base*.

- 1 Fully lower the carriage and remove the load handling attachment.
- 2 Remove the cable retaining fasteners from the winch drum. Remove all of the cable from the drum.
- 3 Lift the machine slightly with an overhead crane. While tilting backwards with the carriage facing up, guide the machine over onto a suitable structure.

▲CAUTION Bodily injury hazard. Use proper lifting techniques when lifting the mast assembly.

▲CAUTION Crushing hazard. The machine may become unbalanced and fall if not properly supported.

- 4 Remove the mounting fastener from the cable anchor at the top of the last column (carriage side).

MAST ASSEMBLY

REV A

- 5 Remove the cable from the mast by pulling on the cable anchor end of the cable.

CAUTION Bodily injury hazard. Cables can fray. Always wear adequate hand protection when handling cable.

- 6 Slide the carriage up approximately 12 inches / 30 cm to expose the column stop mounting fastener, attached to the bottom end of the top column. Remove the fasteners and the column stop.
- 7 **Models with safety brake:** Insert a hex key wrench through the access holes in the carriage to release the safety brake. Position the hex key above the safety brake rollers. Slide the carriage away from the base while pulling back on the wrench.

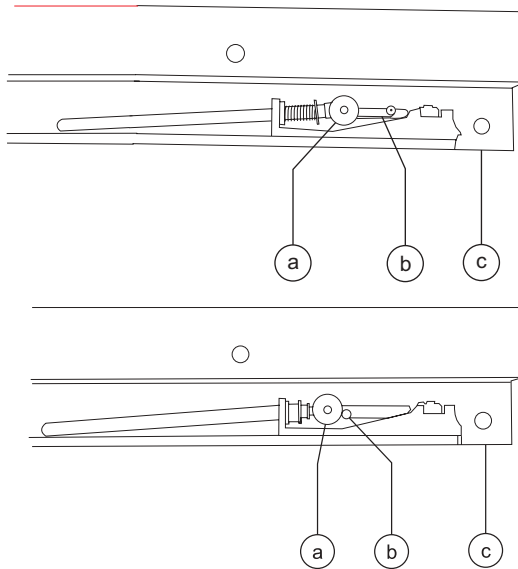

- a Brake roller
b Brake release tool
c Column or carriage

- 8 **Models with safety brake:** Remove the carriage by sliding it out the bottom of the mast toward the base while holding the safety brake rollers in the released position with the hex key wrench.

Models without safety brake: Remove the carriage by sliding it out the bottom of the mast toward the base.

- 9 Slide the column up approximately 12 inches / 30 cm to expose the column stop mounting fasteners attached to the bottom end of the top column. Remove the fasteners and the column stops.
- 10 **Models with safety brake:** Insert a hex key wrench through the access holes in the column up to release the safety brake. Position the hex key above the safety brake rollers. Slide the carriage away from the base while pulling back on the wrench.
- 11 **Models with safety brake:** Remove the column by sliding it out the bottom of the mast toward the base while holding the safety brake rollers in the released position with the hex key wrench.
- Models without safety brake:** Remove the column by sliding it out the bottom of the mast toward the base.
- 12 Repeat steps 10 through 12 for each remaining column.

REV A

MAST ASSEMBLY

How to Release the Safety Brake When Servicing the Mast

The safety brake system can engage when the machine is tilted horizontally if the hold-down bar is not used. When the brake is engaged, the columns can extend but not retract. If the safety brake system engages while you are servicing the mast, use one of the following methods described below to release the brake.

Method A: This method allows you to release each column in sequence, starting at the carriage and removing columns one at a time. See 2-1, *How to Disassemble the Mast Assembly*.

Method B: This method allows you to release any column in the assembly regardless of its position, but requires a custom tool. The tool is a piece of $\frac{1}{8}$ to $\frac{5}{16}$ inch / 3.2 to 8 mm diameter stiff wire bent in an L shape with one end 1 inch / 25mm long and the other end 16 inches / 41 cm long. The installation of a handle on the long end will make it easier to use. This tool is available from Genie Industries (Genie part number 33875).



Insert the tool from the bottom of the column into the safety brake access slot in the inner side wall of the column. Reach through the far upper end of the slot and position the short end of the tool above the safety brake rollers. Slide the carriage away from the base while pulling back on the tool.

How to Assemble the Mast

- 1 Inspect all mast parts for wear and damage. Replace as necessary.
 - 2 Clean all columns and rollers.
 - 3 Clean all safety brake assemblies (if equipped).
 - 4 Position the number one column so that it is open-side up and level. If it is not attached to the base, secure the column to the supports.
 - 5 Install all column assembly components (removed during disassembly) except the column down stops. Apply a small amount of multi-purpose grease between the roller bolt head and the inside of the roller wheel.
 - 6 Slide the number two column into the number one from the bottom. Stop inserting the column when the top of the up stop or the safety brake assembly is even with the bottom edge of the number one column.
 - 7 Repeat steps 4 through 6 with all remaining columns. Do not install the carriage.
- NOTICE** The cable is installed after all columns are together as an assembly.
- 8 Attach the swaged end of the cable to the cable anchor on the top of the front column.

MAST ASSEMBLY

REV A

- 9 Feed the other end of the cable through the box section (web) of the carriage into the pulley, then push the cable through the pulley until it comes out the back side of the carriage.

CAUTION Bodily injury hazard. Cables can fray. Always wear adequate hand protection when handling cable.

NOTICE Refer to Figure 8-D in the Parts Section to identify the cable routing.

- 10 Insert the carriage into the bottom end of the top column. Hold the carriage in place and pull the cable up to the top of the column, leaving enough slack to feed the cable through the next pulley.
- 11 Push the cable through the exposed portion of the pulley at the top of the column until the cable reaches the pulley at the bottom of the column.
- 12 Remove the lower pulley assembly from the upper column.
- 13 Route the cable into and around the lower pulley.
- 14 Apply Loctite® removeable thread sealant to the pulley mounting fastener and install the lower pulley into the column.
- 15 Push the cable between the two mast sections until it comes out the top of the column.
- 16 Repeat steps 11 through 15 with all remaining columns.
- 17 Slide all the columns forward, until you can install the column stops. Do not slide the columns forward any farther than necessary.
- 18 Install all the components removed during disassembly.

NOTICE Be sure that all fasteners have Loctite® removeable thread sealant applied to the threads and that all fasteners have been securely tightened.

- 19 Attach the cable to the winch and be sure the cable is routed correctly.
- 20 Raise the machine to full height to release the safety brakes (if equipped) and verify proper operation.

REV A

MAST ASSEMBLY

2-2 Lifting Cable

How to Replace the Lifting Cable

CAUTION Bodily injury hazard. Cables can fray. Always wear adequate hand protection when handling cable.

NOTICE All Genie replacement cables come with one pre-swaged end that terminates at the top of the last column and one taped end that terminates at the winch.

NOTICE For additional information, refer to instructional video, *Genie Superlift Cabling Procedure*. This video is available from Genie Industries (Genie part number 52701).

- 1 Fully lower the carriage.
- 2 Remove the retaining fasteners from the eyelet end of the cable at the mast anchor plate and cut the eyelet off below the copper sleeve.

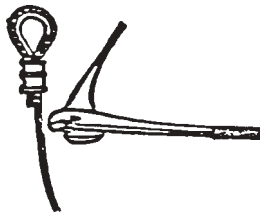

- 3 Remove the old cable from the winch drum.

- 4 Unwind the outer strands and trim them back 1/2 inch / 13 mm leaving the core longer. Repeat this process on the open end of the new cable.

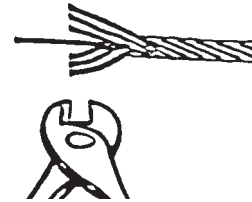

- 5 Using the cable threading tool supplied with your cable, insert even amounts of cable into each end of the tool. Tighten the set screws.

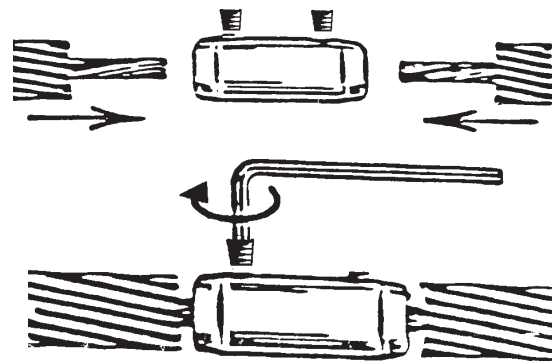

- 6 Place a smooth layer of strapping tape over the joint section of the two cables and the tool.



NOTICE If the cable gets caught as you are pulling it through the columns and pulleys, avoid pulling too hard as you may break the connection between the two cables. Try pulling the cable back and forth until the cable pulls freely.

MAST ASSEMBLY

REV A

- 7 Pull on the old cable while feeding the new cable through the machine.
- 8 When the taped area appears at the winch, loosen the set screws and remove the old cable.
- 9 Attach the new cable to both the mast anchor and the winch drum.
- 10 Wind the new cable evenly onto the winch drum. Be sure there are at least four wraps of cable on the winch drum.
- 11 Fully raise and lower the carriage without a load to check for proper operation. The carriage should raise and lower smoothly.
- 12 Fully raise and lower the carriage again with a load and check for proper operation. The carriage should raise and lower smoothly.

CAUTION Do not use as a load carrying cable splice. This tool is intended for cable replacement only.

2-3 Lifting Pulley

How to Replace a Lifting Pulley - Mast Installed

- 1 Fully lower the carriage.
- 2 Unwind approximately 1 to 2 feet / 30 to 60 cm of cable from the winch drum.
- 3 Tip the machine backwards and rest the top of the number one mast on a suitable structure capable of supporting it. Secure the top of the mast to the structure.
- 4 Attach an overhead crane to the base. Lift the machine to a horizontal position and slide a second structure under the mast next to the base.
- 5 If replacing an upper pulley, slide the column that is above the pulley to be replaced forward. If replacing a lower pulley, slide the column with the pulley to be replaced forward. Push the column forward approximately 6 inches / 15 cm to expose the lower column stop.
- 6 Remove the column stop mounting fasteners.
- 7 Slide the column backwards until the pulley that is to be replaced is exposed.
- 8 Remove the two mounting fasteners from the pulley mounting block. Remove the pulley assembly.
- 9 Remove the retaining fastener that attaches the pulley to the mounting block.

NOTICE Note the quantity and location of the shims and spacers before disassembling.

- 10 Remove the old pulley.
- 11 Install the cable onto the new pulley.

REV A

MAST ASSEMBLY

12 Apply Loctite® removeable thread sealant to the pulley mounting fastener and install the fastener through the pulley and pulley guard into the pulley mounting block.

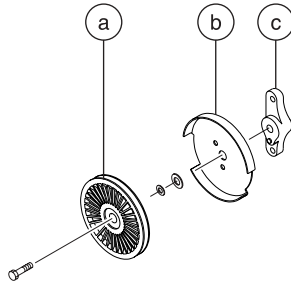

- a pulley
- b pulley guard
- c pulley mounting block

WARNING Crushing hazard. Failure to properly route the cable could result in a winch brake failure.

CAUTION Component damage hazard. Do not allow the cable to become twisted during installation or mast sequencing problems may occur.

NOTICE Be sure the cable guard is located over the retaining pin on the pulley mounting block. Be sure the pulley spins freely after reassembling the pulley assembly.

13 Apply Loctite® removeable thread sealant to the fastener and install the pulley assembly onto the column.

14 Assemble the columns in reverse order of disassembly.

Winches

REV A

3-1 One-speed Winch

How to Disassemble a One-speed Winch

CAUTION Bodily injury hazard. Cables can fray. Always wear adequate hand protection when handling cable.

- 1 Fully lower the carriage.
 - 2 Remove the cable retaining fastener from the winch drum. Remove the cable from the winch drum.
 - 3 Remove both handle retaining fasteners. Remove the handles from the pinion shaft.
 - 4 Remove the drum bolt and the drum bolt spacer. Remove the drum, drum gear cover and housing spacer from the winch.
 - 5 Remove the two lock nuts from the pinion shaft by holding the opposite end of the shaft at the flattened portion of the threads.
- CAUTION** Component damage hazard. Be careful not to damage the threads while holding the pinion shaft.
- 6 Remove the retaining ring from the pinion shaft.
 - 7 Slide the pinion shaft to the right and remove the pinion spacer, pinion plate, ratchet gear and friction disks. Turn the pinion gear counterclockwise and slide it off the left side of the shaft.
 - 8 Remove the pinion shaft from the winch housing.
 - 9 Remove both pinion bushings. Use a soft metal drift equal to the outside diameter of the bushing and tap with a rubber mallet.
- CAUTION** Component damage hazard. Place a block in between the walls of the winch housing to prevent the housing from bending while removing the bushings.
- 10 Remove the winch housing from the machine.

REV A

WINCHES

How to Assemble a One-speed Winch

CAUTION Bodily injury hazard. Cables can fray. Always wear adequate hand protection when handling cable.

NOTICE Refer to Figure 8-E, *One-speed Winch*, for an exploded view of the winch.

- 1 Place one side of the winch housing over the jaws of a vise. Open the vise until the jaws are wider than the outside diameter of the bushing.
- 2 Insert a soft metal drift through the opposite bushing hole. Tap the drift with a rubber mallet to push the bushing into place.
- 3 Repeat steps 1 and 2 to insert the other bushing.

NOTICE Use a piece of flatbar or wood in between the drift and the bushing to prevent any damage to the bushing.

- 4 Add two drops of 30W oil to both pivot points on each ratchet pawl.

CAUTION Component damage hazard. Do not allow grease or oil onto the brake disks or the ratchet gear.

- 5 Install the winch housing onto the mast. Be sure the winch drum is toward the top.
- 6 Insert the longer threaded end of the pinion shaft approximately halfway through the left bushing.

- 7 Apply a small amount of multi-purpose grease to the large threaded section of the pinion shaft, under the gear nut. Screw the pinion gear onto the pinion shaft with the gears toward the left side of the winch housing.

- 8 Install, in order, a brake disk, a ratchet gear, a brake disk, a pinion plate and a pinion spacer onto the pinion shaft.

CAUTION Component damage hazard. Do not allow grease or oil onto the brake disks or the ratchet gear.

NOTICE The teeth on the ratchet gear must curve away from the right side of the winch housing.

- 9 Push the pinion shaft to the right, through the right pinion bushing, and install the pinion shaft retaining ring.

NOTICE Use your fingers to push the ratchet pawls outward while pushing the pinion shaft through the right bushing. Be sure the ratchet pawls are in firm contact with the ratchet gear and that all parts move freely.

- 10 Install the two jam nuts to the right side of the pinion shaft one at a time, and tighten.
- 11 Position both handles on the pinion shaft in opposite directions. Install and tighten the lock nuts.

WINCHES

REV A

- 12 Lubricate the outside of the frame spacer with multi-purpose grease. Insert the frame spacer into the drum.
- 13 Install the cable drum. Be sure the drum gears mesh with the ratchet gears.
- 14 Install the drum bolt keeper. Push the drum bolt through the winch housing, drum cover and drum. Be sure the head of the drum bolt is on the drum gear side of the winch.
- 15 Place the drum gear cover in position with the drum bolt slot under the drum bolt keeper.
- 16 Install the drum bolt jam nut hand tight.
- 17 Install the housing spacer with the head of the housing spacer bolt on the right side of the winch and through the slotted portion of the drum gear cover. Place the nut on the end of the bolt and tighten.
- 18 Torque the drum bolt nut to
20 to 25 ft-lbs / 27 to 34 Nm.

CAUTION Component damage hazard. Overtightening the drum bolt jam nut may cause damage to the frame spacer and prevent the drum from spinning freely.

- 19 Lubricate the teeth of the drum gear and the pinion nut that meshes with the drum gear with multi-purpose grease.

CAUTION Component damage hazard. Do not allow grease or oil onto the friction disks or the ratchet gear.

- 20 Rotate the drum so that the two square cable keeper holes are at the top. Install the cable keeper clip to the outside of the drum with the two carriage bolts coming through from the inside. Install the lock washers and nuts finger tight. Do not tighten.
- 21 Route the end of the cable around the winch drum and out through the remaining hole on the left side wall of the drum.

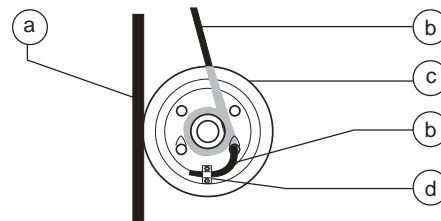

- a number one column
- b cable
- c winch drum
- d cable keeper clip

- 22 Insert the end of the cable under the cable keeper clip approximately $\frac{1}{2}$ inch / 13 mm and tighten the cable keeper clip fasteners.
- 23 While holding the cable tight on the drum, rotate the drum and spool the cable onto the drum evenly.

CAUTION Component damage hazard. Be sure the cable winds onto the winch drum evenly.

REV A

WINCHES

3-2 Two-speed Winch

How to Disassemble a Two-speed Winch

CAUTION Bodily injury hazard. Cables can fray. Always wear adequate hand protection when handling cable.

- 1 Fully lower the carriage and remove the load handling attachment.
- 2 Remove the cable retaining fasteners from the winch drum. Remove the cable from the drum.
- 3 Remove both handle retaining fasteners from the pinion shaft. Remove the handles.
- 4 Remove the drum bolt and spacer. Remove the drum, drum gear cover and housing spacer.
- 5 Remove the input shaft cover.
- 6 Remove the mounting fasteners from the spring and ball housing.
- 7 Remove the two springs and balls from the spring and ball housing.
- 8 Slide the input shaft out of the winch housing.
- 9 Remove the retaining ring from the pinion shaft.
- 10 Remove the lock nut from the end of the pinion shaft (located on the outside of the winch housing).

NOTICE Note the location and position of the components on the pinion shaft.

- 11 Slide the pinion shaft to the right and remove the pinion spacer, pinion plate, ratchet gear, and friction disks. Turn the pinion gear counterclockwise and slide it off the left side of the shaft.
- 12 Remove both pinion bushings. Use a soft metal drift equal to the outside diameter of the bushing and tap with a rubber mallet.

CAUTION Component damage hazard. Place a block between the walls of the winch housing to prevent the housing from bending while removing the bushings.

WINCHES

REV A

How to Assemble a Two-speed Winch

CAUTION Bodily injury hazard. Cables can fray. Always wear adequate hand protection when handling cable.

NOTICE Refer to Figure 8-F, *Two-speed Winch*, for exploded view of the winch.

- 1 Place one side of the winch housing over the jaws of a vise. Open the vise until the jaws are wider than the outside diameter of the bushing.
- 2 Insert a soft metal drift through the opposite bushing hole. Line up the tab on the bushing to the hole in the winch housing. Tap the drift with a rubber mallet to push the bushing into place.
- 3 Repeat steps 1 and 2 to insert the other bushing.

NOTICE Use a piece of flatbar or wood between the drift and the bushing to prevent any damage to the bushing.

- 4 Add two drops of 30W oil to both pivot points on each ratchet pawl.

CAUTION Component damage hazard. Do not allow grease or oil onto the friction disks or the ratchet gear.

- 5 Install the winch housing on the mast. Be sure the winch drum is toward the top.
- 6 Insert the longer threaded end of the pinion shaft approximately halfway through the right side bushing.

- 7 Apply a small amount of multi-purpose grease to the large threaded section of the pinion shaft, under the gear nut. Slide the pinion shaft gears onto the pinion shaft. Install the pinion gear onto the pinion shaft with the gears toward the right side of the winch housing. Screw onto large threads hand tight.

- 8 Install, in order, a friction disk, a ratchet gear, a friction disk, a pinion plate and a pinion spacer onto the pinion shaft.

CAUTION Component damage hazard. Do not allow grease or oil onto the brake disk, ratchet gear or the teflon spacer.

NOTICE The teeth on the ratchet gear must curve toward the left side of the winch housing.

- 9 Install the pinion shaft retaining ring onto the pinion shaft.

NOTICE Use your fingers to push the ratchet pawls outwards while pushing the pinion shaft through the left bushing. Be sure the ratchet pawls are in firm contact with the ratchet gear and that all parts move freely.

- 10 Install the lock nut on the left side of the pinion shaft.

- 11 Install the input shaft approximately half way through the left side of the winch housing.

- 12 Slide the left side bushing, spring and ball housing, spacer, input shaft gears and right side bushing onto the input shaft.

REV A

WINCHES

- 13 Install the ball and spring into the spring and ball housing. Install the mounting fasteners.
- 14 Lubricate the outside of the frame spacer with multi-purpose grease and insert it into the drum.
- 15 Install the cable drum. Be sure the drum gears mesh with the ratchet gears.
- 16 Install the drum bolt keeper. Push the drum bolt through the winch housing, drum cover and drum. Be sure the head of the drum bolt is on the drum gear side of the winch.
- 17 Install the drum bolt jam nut and torque to 20 to 25 ft-lbs / 27 to 34 Nm.

CAUTION Component damage hazard. Overtightening the drum bolt jam nut may cause damage to the frame spacer and prevent the drum from spinning freely.

- 18 Lubricate the teeth of the drum gear and the pinion nut with multi-purpose grease.

CAUTION Component damage hazard. Do not allow grease or oil onto the friction disks or the ratchet gear.

- 19 Install the input shaft cover.
- 20 Rotate the winch drum so that the oblong slot is visible and horizontal.
- 21 Install the cable keeper clip on the outside of the winch drum with one carriage bolt coming through from the inside. Install the lock washer and nut finger tight. Do not tighten the nut.

- 22 Route the end of the cable between the winch drum and the number one column. Proceed around the drum and up through the horizontal slot in the winch drum. The cable is then fed under the lefthand side of the cable clip, pulled forward, looped, and then fed under the right hand side of the cable keeper clip. The raw end of the cable is then fed into the righthand side of the horizontal slot in the winch drum.

WARNING Crushing hazard. Failure to properly route the cable may result in a winch brake failure.

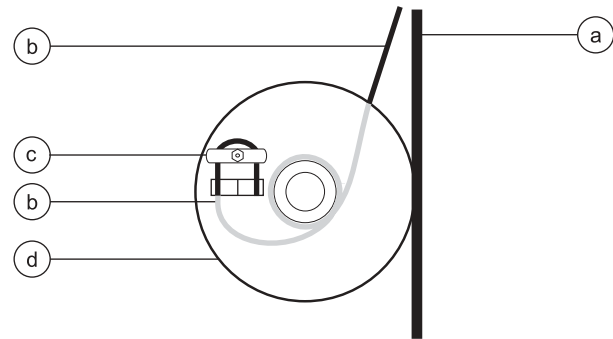

- a Number one column
b Cable
c Cable keeper clip
d Winch drum

- 23 Tighten the cable keeper fastener.
- 24 While holding the cable tight on the drum, rotate the drum with a handle and spool the cable onto the drum evenly.

CAUTION Component damage hazard. Be sure the cable winds onto the winch drum evenly.



This page intentionally left blank.

Section Six

Decals

Figure 6-A

REV B

Decals with Words (before serial number SLA04-25259)

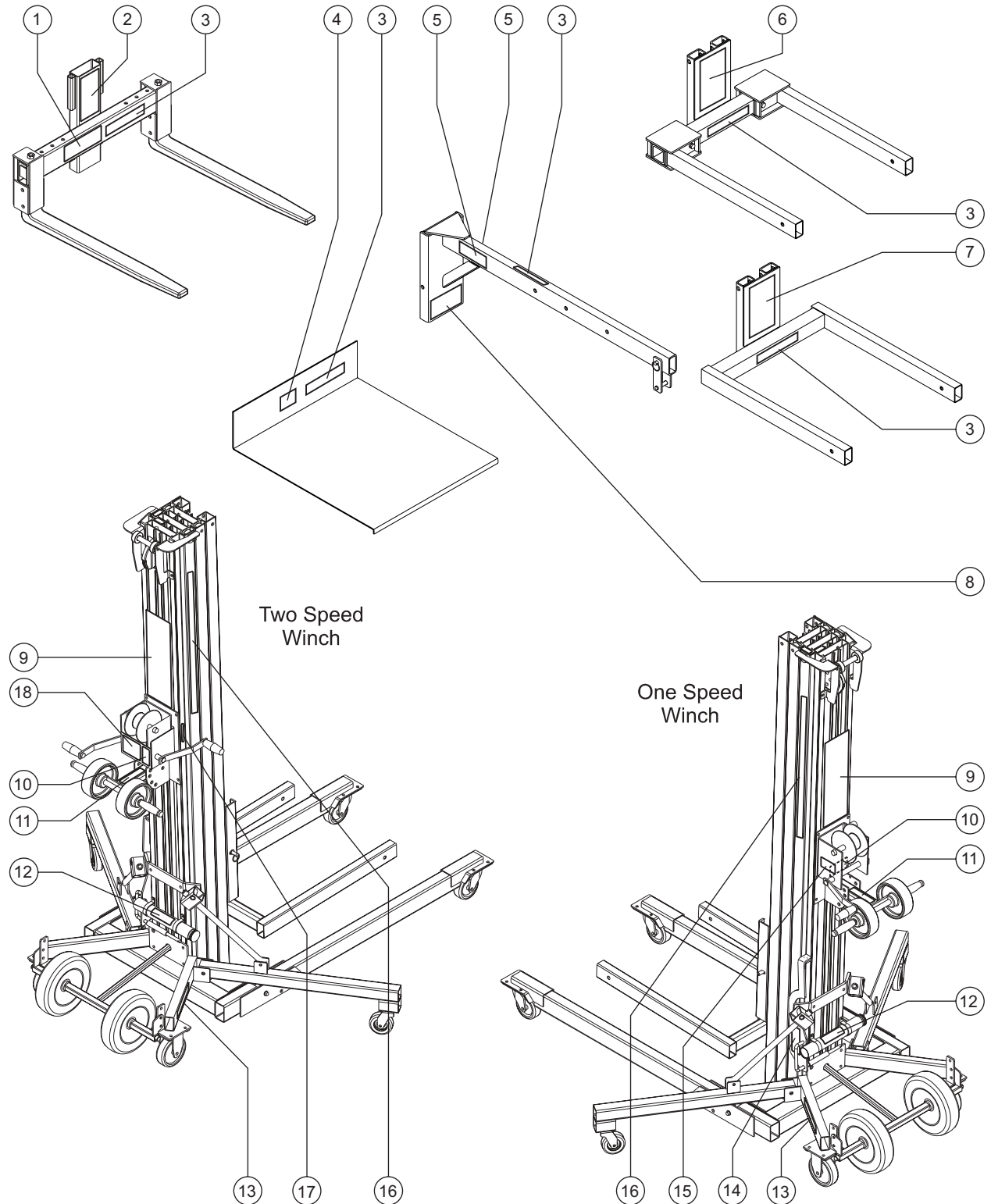

REV B

FIGURE 6-A

Item	Part No.	Description	Qty.
1	32715	Notice - Flat Fork Setup	1
2	32718	Warning - Flat Fork Safety	1
3	33468	Warning - No Riders	5
4	32775	Warning - Fall Hazard	1
5	32716	Notice - Boom Setup	2
6	32714	Notice - Adjustable Fork Setup	1
7	32687	Warning - Standard Fork Safety ...	1
8	32717	Warning - Boom Safety	1
9	32686	Warning - Machine Safety	1
10	32938	Label - Use this Winch	1
11	32939	Warning - Crushing Hazard, Brake Lock	1
12	31072	Label - Operator's Manual Storage Container	1
13	32689	Cosmetic (SLA-5)	2
—	32690	Cosmetic (SLA-10)	
—	32691	Cosmetic (SLA-15)	
—	32692	Cosmetic (SLA-20)	
—	32693	Cosmetic (SLA-25)	
14	52675	Caution - Damaged Machine	1
15	32885	Warning - Silent Winch	1
16	52983	Cosmetic - Superlift Advantage	2
17	33982	Plate - Serial Number (before serial number SLA03-20337)	1
—	80939	Plate - Serial Number (after serial number SLA03-20336)	
18	32770	Label -Two-speed Winch	1

Figure 6-B

REV B

Decals with Words (after serial number SLA04-25258)

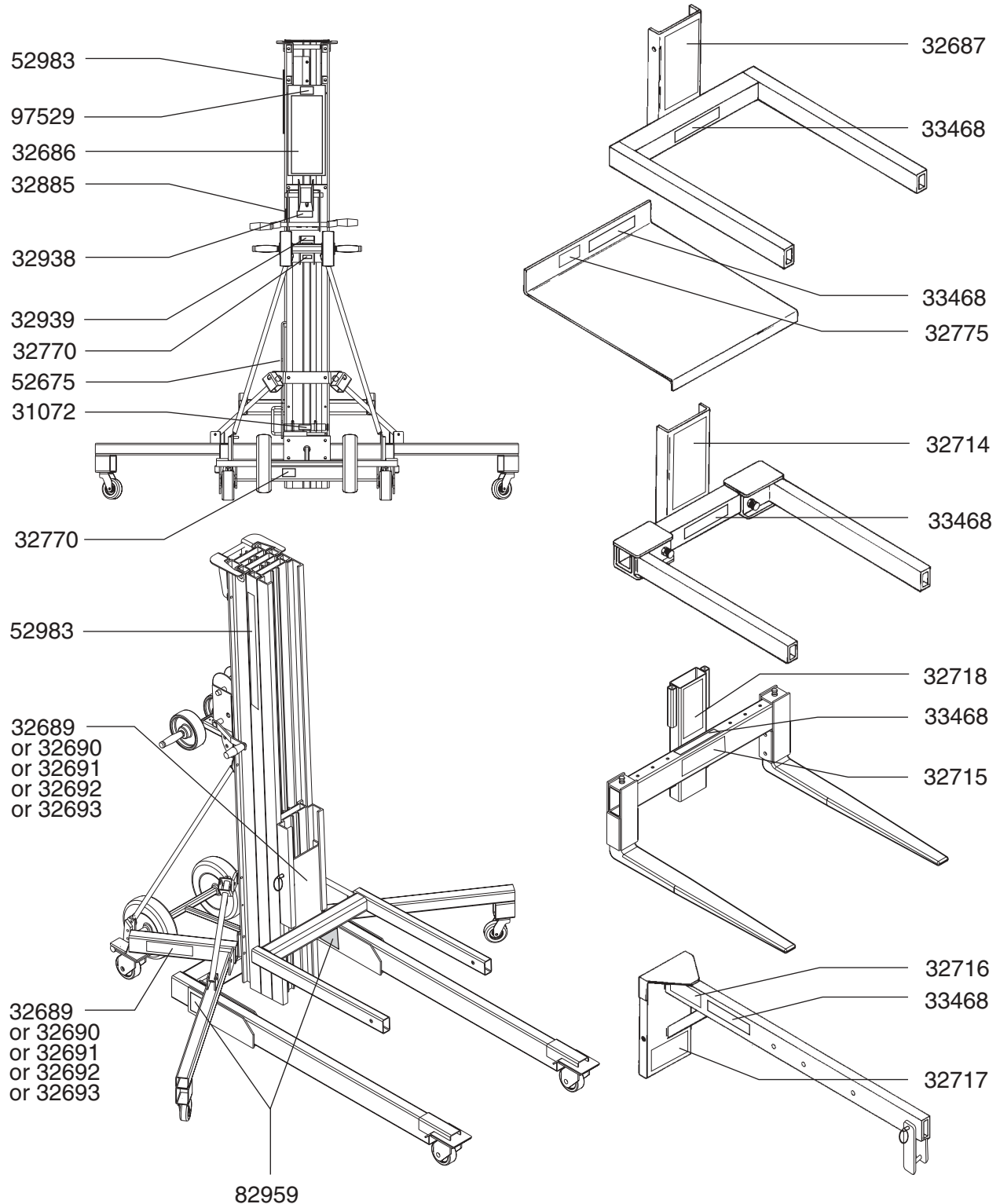

REV B

FIGURE 6-B

Item	Part No.	Description	Qty.
1	31072	Label - Operator's Manual Container	1
2	32686	Warning - Machine Safety	1
3	32687	Warning - Standard Fork Safety ...	1
4	32689	Cosmetic (SLA-5)	2
—	32690	Cosmetic (SLA-10)	
—	32691	Cosmetic (SLA-15)	
—	32692	Cosmetic (SLA-20)	
—	32693	Cosmetic (SLA-25)	
5	32714	Notice - Adjustable Fork Setup	1
6	32715	Notice - Flat Fork Setup	1
7	32716	Notice - Boom Setup	1
8	32717	Warning - Boom Safety	1
9	32718	Warning - Flat Fork Safety	1
10	32770	Label -Two-speed Winch	1
11	32775	Warning - Fall Hazard	1
12	32885	Warning - Silent Winch	1
13	32938	Label - Use this Winch	1
14	32939	Warning - Crushing Hazard, Brake Lock	1
15	33468	Warning - No Riders	5
16	52675	Caution - Damaged Machine	1
17	52983	Cosmetic - Superlift Advantage	2
18	82959	Danger - Electrocution Hazard	2
19	97529	Caution - Bodily Injury Hazard	1
20	33982	Plate - Serial Number (before serial number SLA03-20337)	1
—	80939	Plate - Serial Number (after serial number SLA03-20336)	

Figure 6-C

REV B

Decals with Symbols

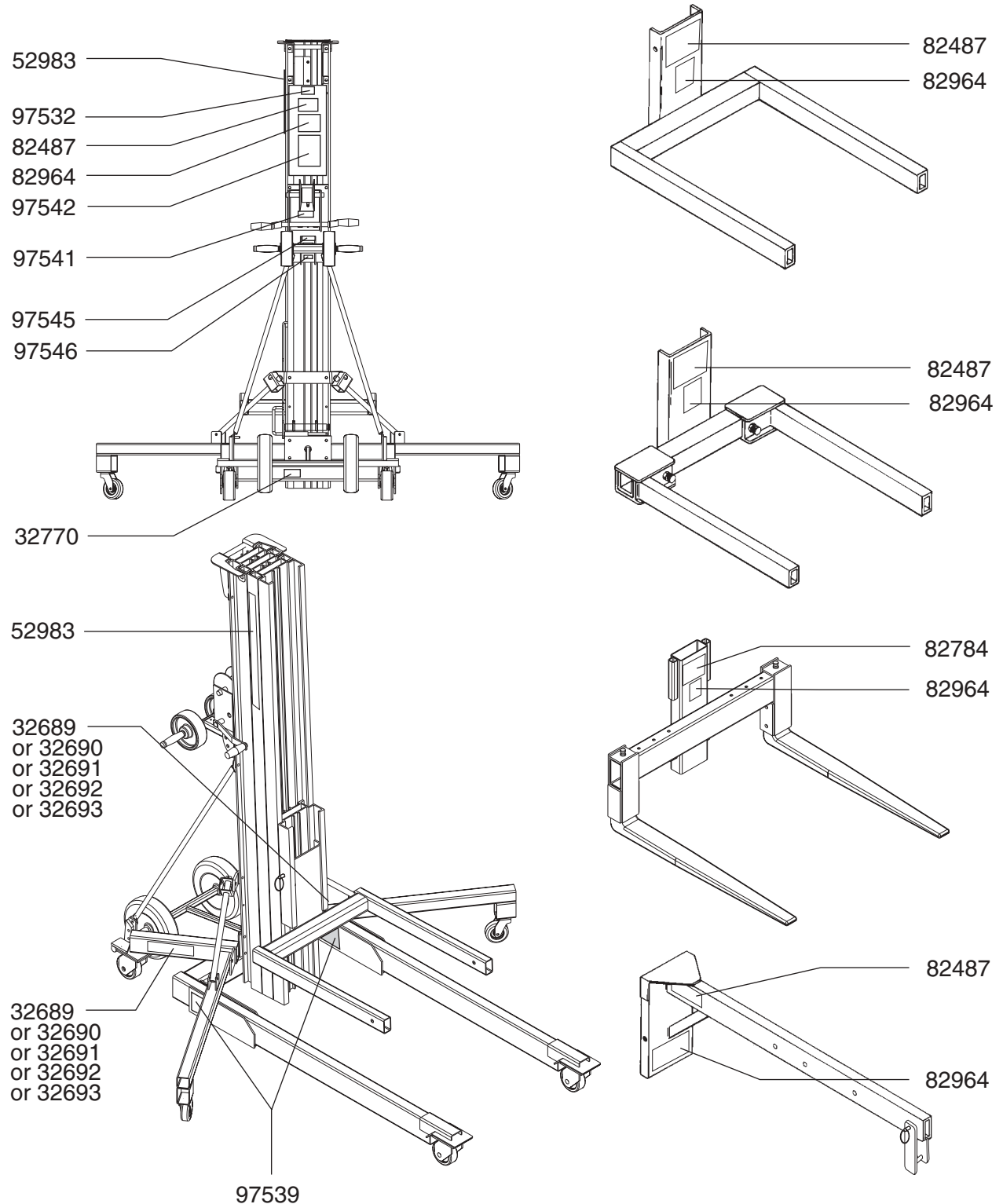

REV B

FIGURE 6-C

Item	Part No.	Description	Qty.
1	32689	Cosmetic (SLA-5)	2
—	32690	Cosmetic (SLA-10)	
—	32691	Cosmetic (SLA-15)	
—	32692	Cosmetic (SLA-20)	
—	32693	Cosmetic (SLA-25)	
2	52983	Cosmetic - Superlift Advantage	2
3	82487	Label - Read the Manual	2
4	82964	Warning - No Riders	1
5	97532	Caution - Bodily Injury Hazard	1
6	97539	Danger - Electrocutation Hazard	2
7	97541	Label - Use this Winch	1
8	97542	Warning - Load Center Chart	1
9	97545	Warning - Lock Brake	1
10	97546	Label - Two-speed Shift	1
11	33982	Plate - Serial Number (before serial number SLA03-20337)	1
—	80939	Plate - Serial Number (after serial number SLA03-20336)	

Section Seven

Base Components

Figure 7-A

Base Components - Standard

REV B

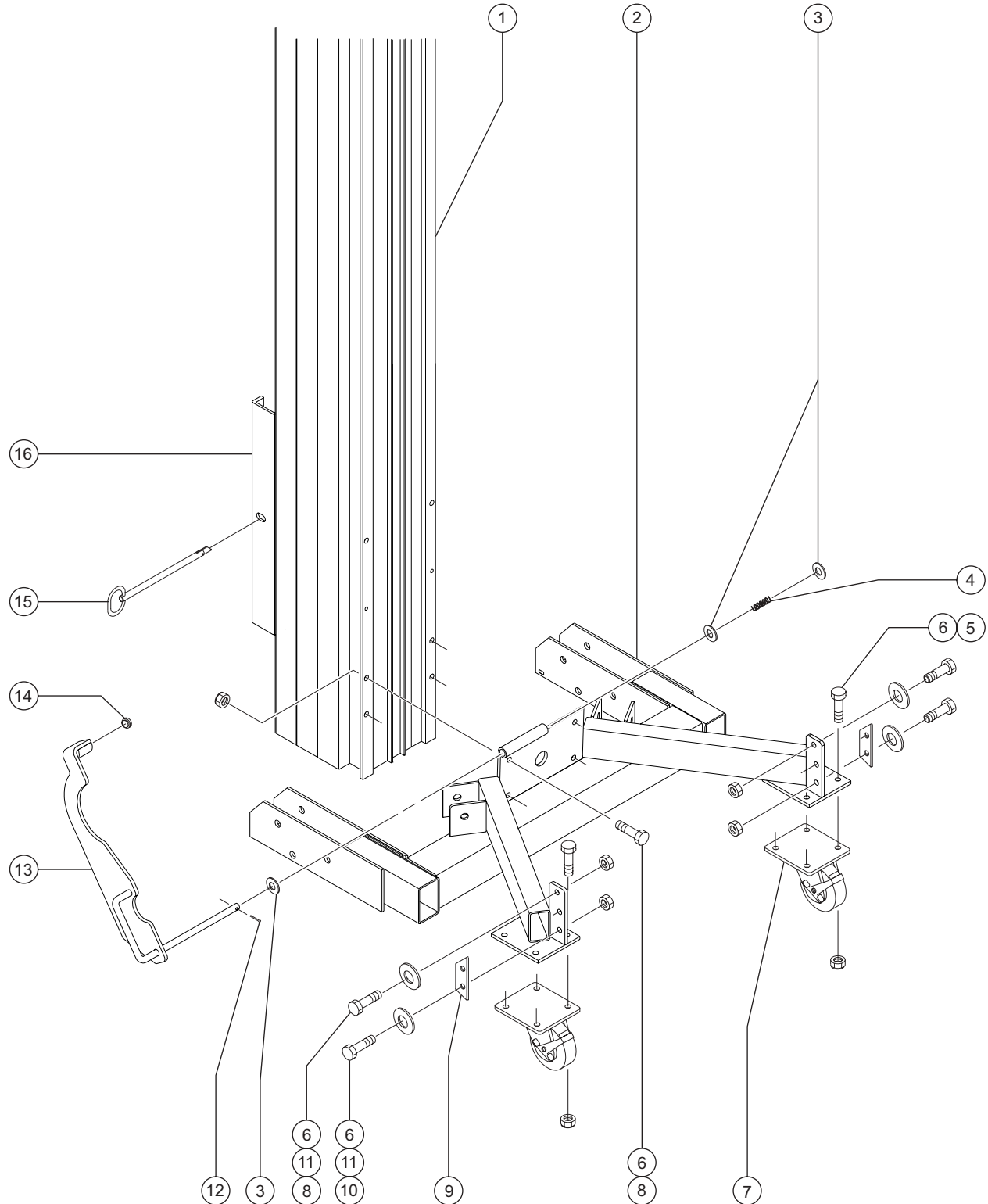

REV B

FIGURE 7-A

Item	Part No.	Description	Qty.	Item	Part No.	Description	Qty.
1	Ref.	Columns (refer to Figure 8-D)		2	107174	Standard Base Assembly with Decals (SLA-20) (after serial number SL04-25258) (USA, Canadian and Australian models after serial number SLA04-25258)	
2	80171-S	Standard Base Assembly with Decals (SLA-5) (before serial number SL04-25259)		—	107184	Standard Base Assembly with Decals (SLA-20) (after serial number SL04-25258) (Asia, S. America and European models after serial number SLA04-25258)	
—	107171	Standard Base Assembly with Decals (SLA-5) (after serial number SL04-25258) (USA, Canadian and Australian models after serial number SLA04-25258)		—	80175-S	Standard Base Assembly with Decals (SLA-25) (before serial number SL04-25259)	
—	107181	Standard Base Assembly with Decals (SLA-5) (after serial number SL04-25258) (Asia, S. America and European models after serial number SLA04-25258)		—	107175	Standard Base Assembly with Decals (SLA-25) (after serial number SL04-25258) (USA, Canadian and Australian models after serial number SLA04-25258)	
—	80172-S	Standard Base Assembly with Decals (SLA-10) (before serial number SL04-25259)		—	107185	Standard Base Assembly with Decals (SLA-25) (after serial number SL04-25258) (Asia, S. America and European models after serial number SLA04-25258)	
—	107172	Standard Base Assembly with Decals (SLA-10) (after serial number SL04-25258) (USA, Canadian and Australian models after serial number SLA04-25258)		3	21443	Shim Washer, 0.45 x 0.75 x 0.063 inch 3	
—	107182	Standard Base Assembly with Decals (SLA-10) (after serial number SL04-25258) (Asia, S. America and European models after serial number SLA04-25258)		4	33658	Hold-down Spring 1	
—	80173-S	Standard Base Assembly with Decals (SLA-15) (before serial number SL04-25259)		5	6175	Screw - HHC, 3/8 -16 x 1 inch, GR 5	
—	107173	Standard Base Assembly with Decals (SLA-15) (after serial number SL04-25258) (USA, Canadian and Australian models after serial number SLA04-25258)		6	4828	Nylock Nut, 3/8 -16	
—	107183	Standard Base Assembly with Decals (SLA-15) (after serial number SL04-25258) (Asia, S. America and European models after serial number SLA04-25258)		7	57740	Rear Swivel Caster, 5 x 2 inches 2	
—	80174-S	Standard Base Assembly with Decals (SLA-20) (before serial number SL04-25259)		8	6019	Screw - HHC, 3/8 -16 x 1.25 inches, GR 5	
				9	33670	Wear Pad, 4.16 x 1.25 x 0.5 inch 2	
				10	8516	Screw - HHC, 3/8 -16 x 1.5 inches, GR 5	
				11	6097	Flat Washer, 3/8 inch	
				12	12016	Cotter Pin, 0.125 x 0.75 inch 1	

This list continues on the next page.

FIGURE 7-A

REV B

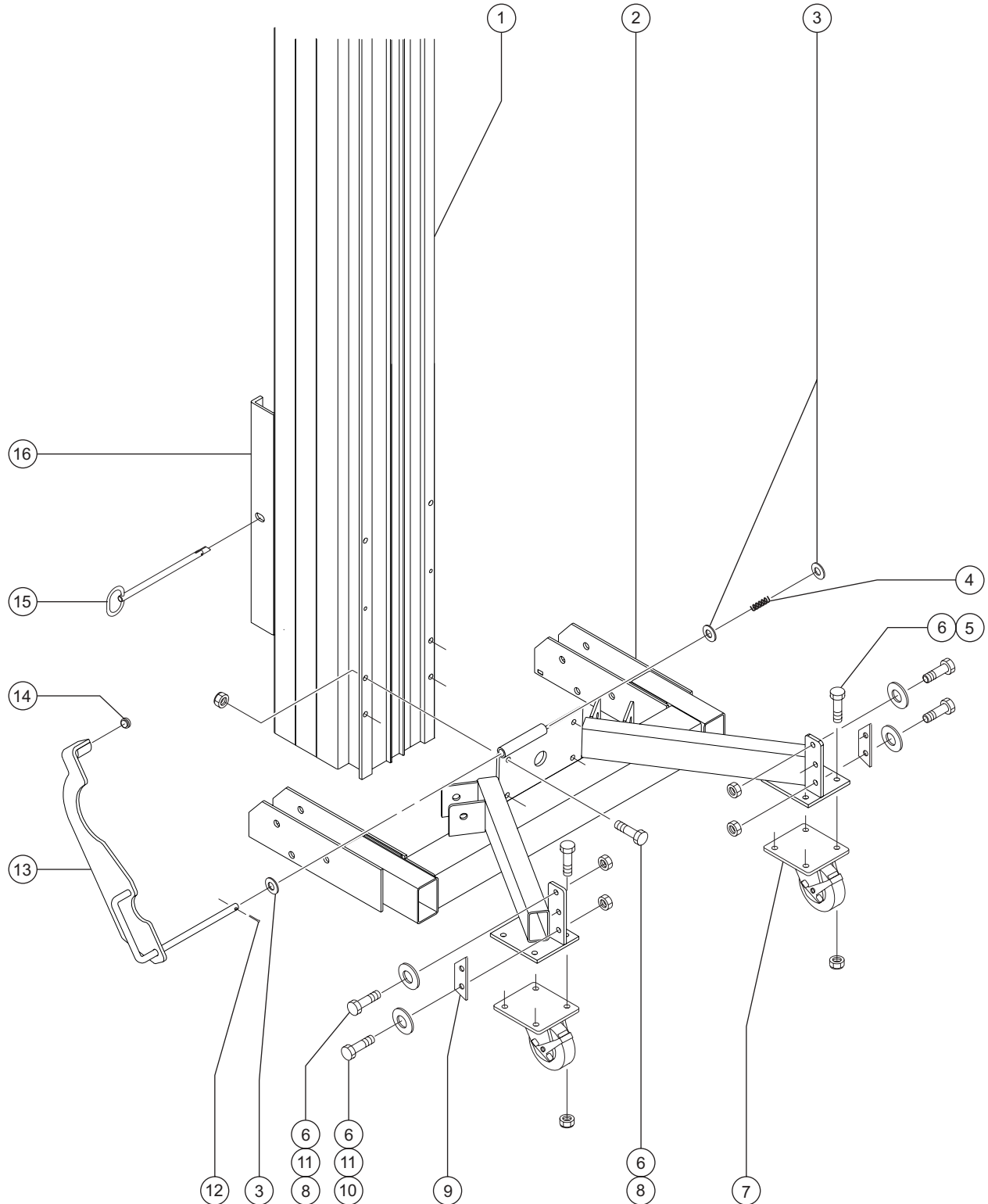

REV B

FIGURE 7-A

Item	Part No.	Description	Qty.
13	58750	Hold-down Assembly with Decals (SLA-5, SLA-10 and SLA-15) (before serial number SLA04-25259) (USA, Canadian and Australian models after serial number SLA04-25258) (includes items 12 and 14)	
—	107153	Hold-down Assembly with Decals (SLA-5, SLA-10 and SLA-15) (Asia, S. America and European models after serial number SLA04-25258) (includes items 12 and 14)	
—	58095	Hold-down Assembly with Decals (SLA-20 and SLA-25) (before serial number SLA04-25289) (USA, Canadian and Australian models after serial number SLA04-25258) (includes items 12 and 14)	
—	107154	Hold-down Assembly with Decals (SLA-20 and SLA-25) (Asia, S. America and European models after serial number SLA04-25258) (includes items 12 and 14)	
14	11890	Glide Button	1
15	38696	Toggle Pin, 0.5 x 7.75 inches	1
16	Ref.	Carriage (refer to Figure 8-D)	

Figure 7-B

Base Components - Straddle (SLA-5, SLA-10 and SLA-15)

REV B

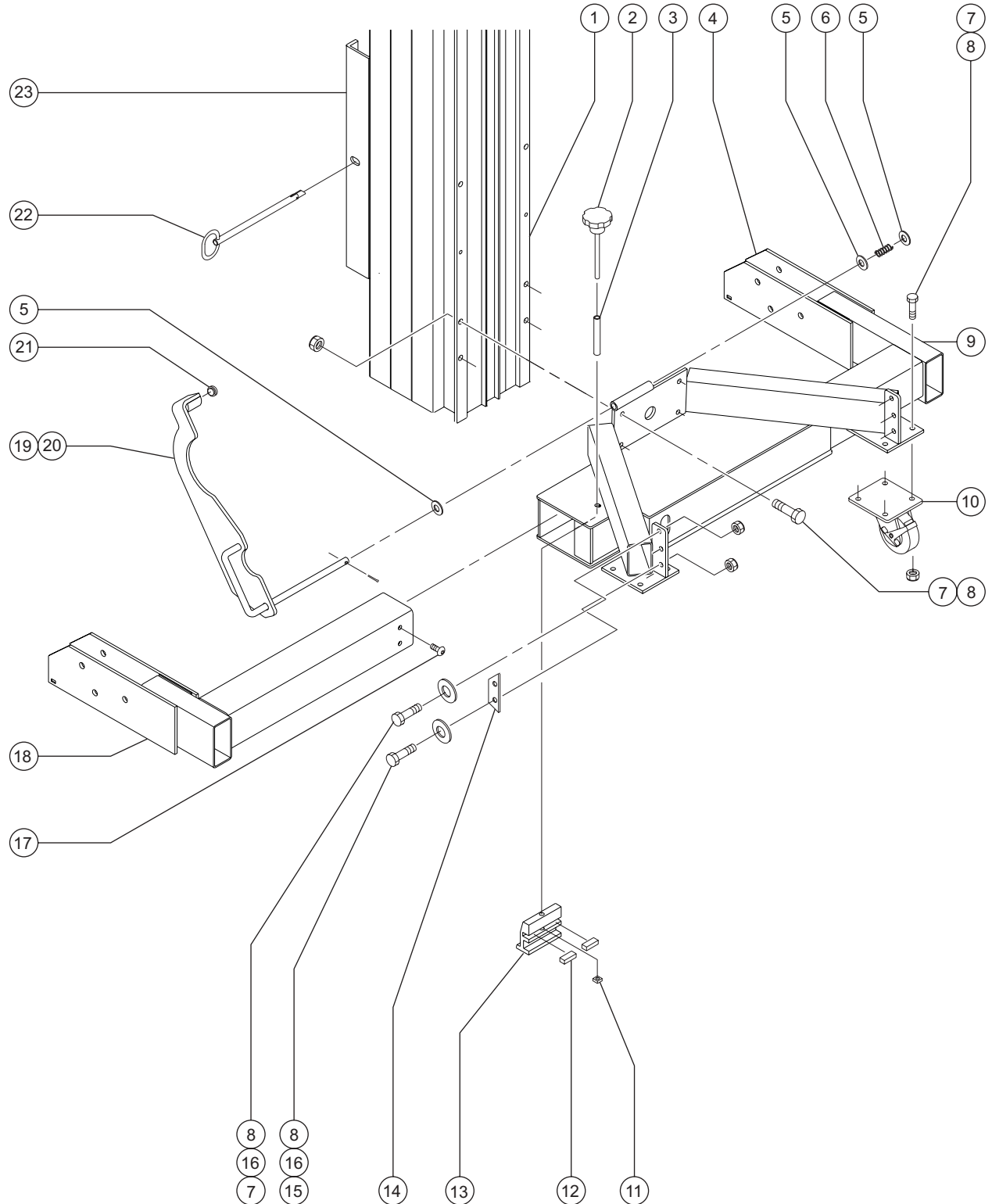

REV B

FIGURE 7-B

Item	Part No.	Description	Qty.	Item	Part No.	Description	Qty.
1	Ref.	Columns (refer to Figure 8-D)		19	107153	Hold-down Assembly with Decals (SLA-5, SLA-10 and SLA-15) (Asia, S. America and European models after serial number SLA04-25258) (includes items 12 and 14)	
2	33148	Straddle Base Knob	2				
3	33251	Straddle Base Spacer, 3 inches	2				
4	32531	Arm Straddle, Right Side	1				
5	21443	Shim Washer, 0.45 x 0.75 x 0.063 inch	3	20	12016	Cotter Pin, 0.125 x 0.75 inch	1
6	33658	Hold-down Spring	1	21	11890	Glide Button	1
7	6019	Screw - HHC, 3/8 -16 x 1.25 inches, GR 5		22	48301	Toggle Pin, 0.5 x 8.13 inches	1
8	4828	Nylock Nut, 3/8 -16		23	Ref.	Carriage (refer to Figure 8-D)	
9	80176-S	Straddle Base Assembly (SLA-5)	1				
—	80177-S	Straddle Base Assembly (SLA-10)					
—	80178-S	Straddle Base Assembly (SLA-15)					
10	57740	Rear Swivel Caster, 5 x 2 inches	2				
11	35408	Square Nut, 3/8 -16					
12	46683	Straddle Retaining Block	4				
13	40255	Straddle Base Wedge	2				
14	33670	Wear Pad, 4.16 x 1.25 x 0.5 inch	2				
15	8516	Screw - HHC, 3/8 -16 x 1.5 inches, GR 5					
16	6097	Flat Washer, 3/8 inch					
17	28487	Screw - BHHS, 3/8 -16 x 1 inch					
18	32532	Arm Straddle, Left Side	1				
19	58750	Hold-down Assembly with Decals (SLA-5, SLA-10 and SLA-15) (before serial number SLA04-25259) (USA, Canadian and Australian models after serial number SLA04-25258) (includes items 12 and 14)					

Figure 7-C

REV C

Base Components - All Models

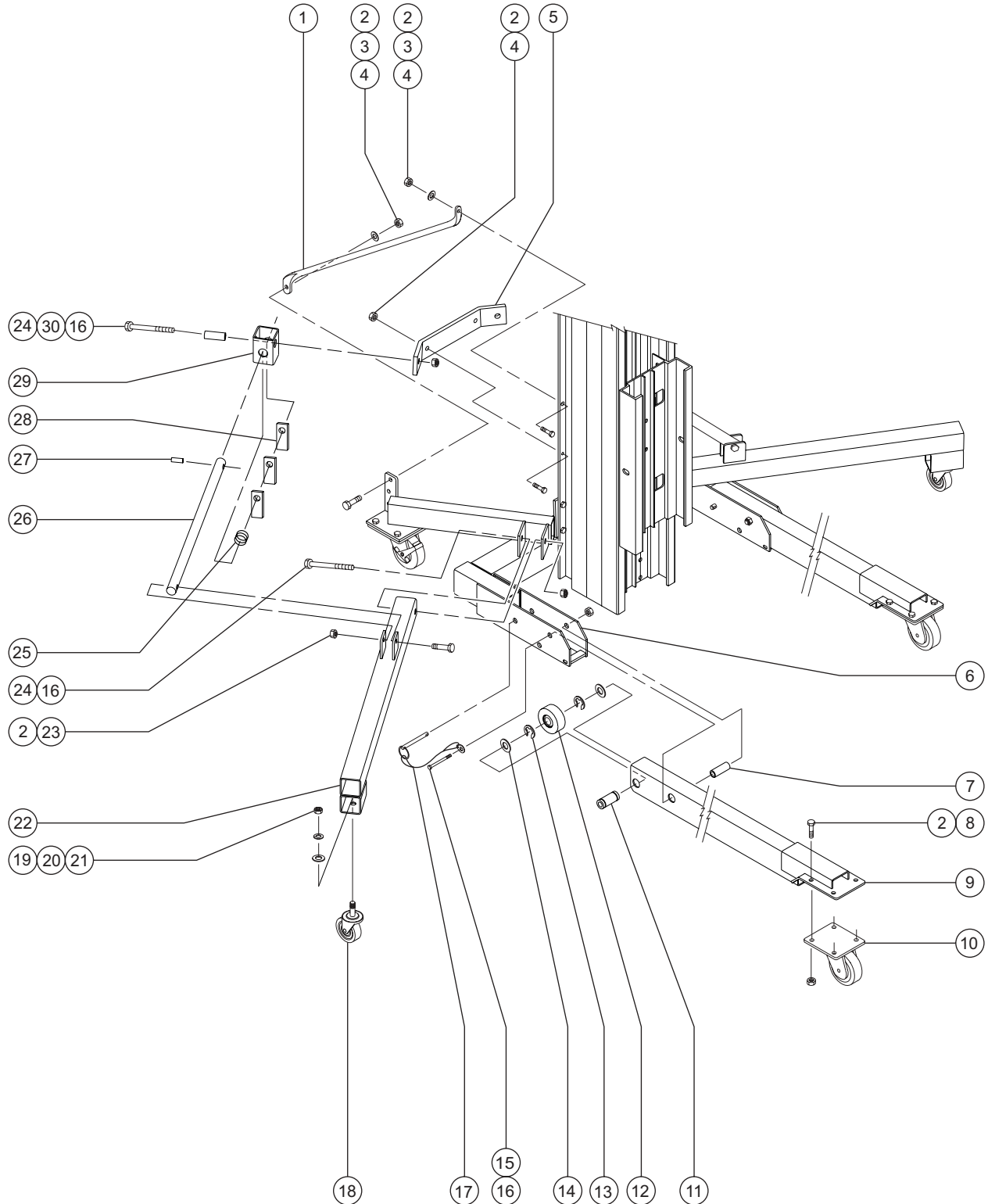

REV C

FIGURE 7-C

Item	Part No.	Description	Qty.	Item	Part No.	Description	Qty.
—	37481	Stabilizer Set Assembly (includes items 2 - 5, 16, 18 and 22 - 30)		24	6732	Screw - HHC, 1/2 -13 x 3.25 inches, GR 5	
1	32883	Mast Brace, Right Side	1	25	32519	Stabilizer Latch Spring	2
—	32884	Mast Brace, Left Side		26	58094	Stabilizer Strut Assembly (includes item 27)	2
2	4828	Nylock Nut, 3/8 -16		27	11337	Roll Pin, 0.25 x 1.25 inches	2
3	6097	Flat Washer, 3/8 inch		28	32577	Stabilizer Latch Plate	6
4	6019	Screw - HHC, 3/8 -16 x 1.25 inches, GR 5		29	32578P	Stabilizer Tube	2
5	35212-S	Stabilizer Mount Bracket	1	30	32576	Stabilizer Pivot Tube	2
6	Ref.	Standard Base Assembly with Decals (refer to Figure 7-A)					
7	32509	Leg Pivot Tube	2				
8	6175	Screw - HHC, 3/8 -16 x 1 inch, GR 5					
9	32879	Leg (SLA-5 and SLA-10)	2				
—	32880	Leg (SLA-15)					
—	32881	Leg (SLA-20 and SLA-25)					
10	57736	Front Swivel Caster, 4 x 2 inches	2				
11	32524	Leg Axle Tube	2				
12	57783	Wheel, 3.5 x 1.25 inches	2				
13	32499	E Clip, 0.875 inch	4				
14	33373	Shim Washer, 0.938 x 1.5 x 0.09 inch	4				
15	10598	Screw - HHC, 1/2 -13 x 3 inches, GR 5					
16	6086	Low Profile Nylock Nut, 1/2 -13					
17	100309	Pin Assembly with Lanyard	2				
18	57746	Side Swivel Caster, 3.5 x 1.25 inches	2				
19	6034	Hex Jam Nut, 1/2 -13					
20	6033	Lock Washer, 1/2 inch					
21	6095	Flat Washer, 1/2 inch					
22	32882	Leg Stabilizer	2				
23	5224	Screw - HHC, 3/8 -16 x 2 inches, GR 5					

Section Eight

Mast and Winch Components

Figure 8-A

REV B

Mast Components, View 1

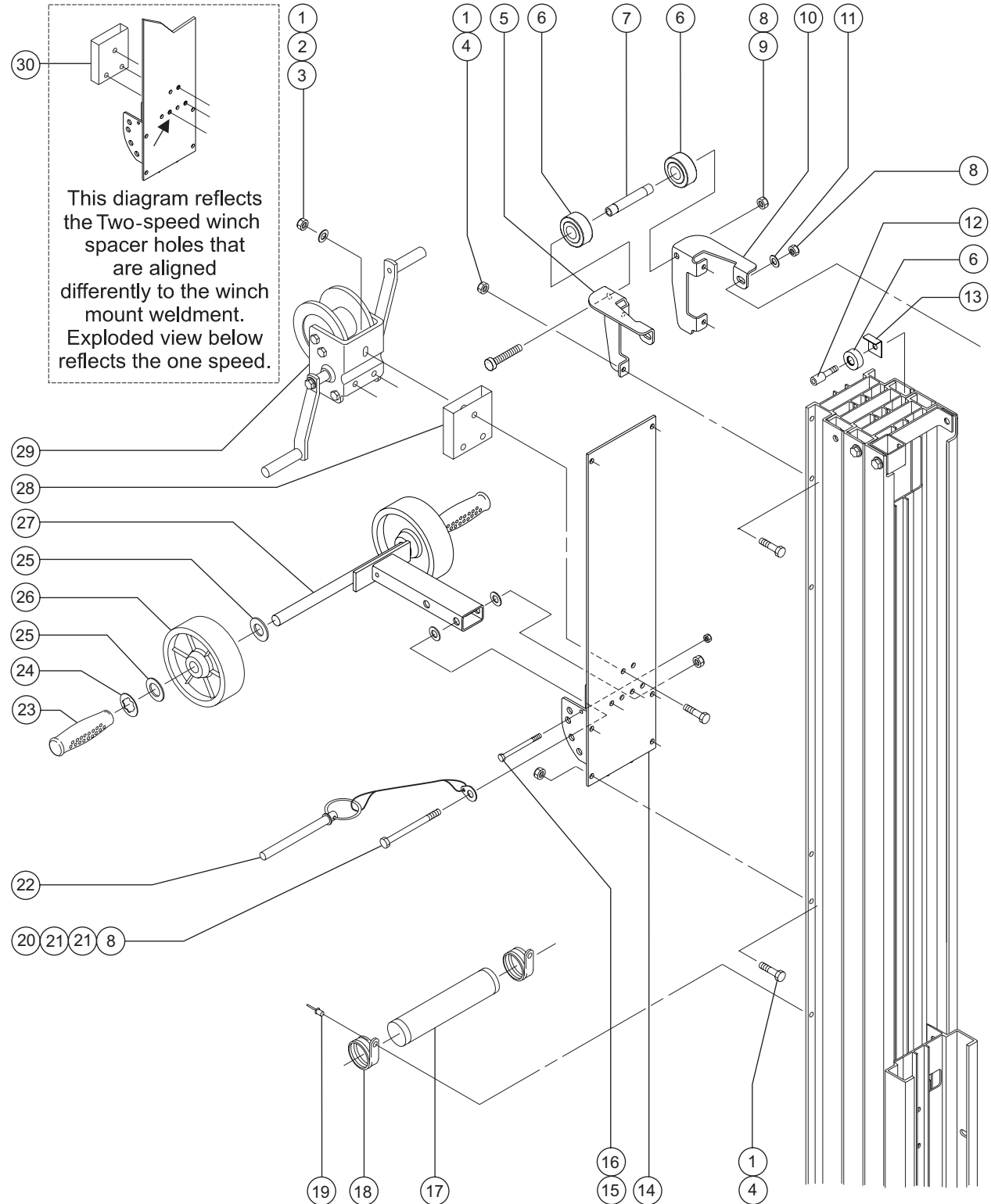

REV B

FIGURE 8-A

Item	Part No.	Description	Qty.	Item	Part No.	Description	Qty.
1	4828	Nylock Nut, 3/8 -16		15	12343	Screw - HHC, 1/4 -20 x 3 inches, GR 5	
2	6097	Flat Washer, 3/8 inch (One-speed winch)		16	6091	Nylock Nut, 1/4 -20	
—	6097	Flat Washer, 3/8 inch (Two-speed winch)		17	6600	Instruction Tube with Caps	1
3	6326	Screw - HHC, 3/8 -16 x 3 inches, GR 5 (SLA-5 and SLA-10)		—	31822	Tube Cap	
—	6175	Screw - HHC, 3/8 -16 x 1 inch, GR 5 (SLA-15, SLA-20 and SLA-25)		18	6653	Rubber Cushioned Clamp, 1.88 inches.....	2
4	6019	Screw - HHC, 3/8 -16 x 1.25 inches, GR 5		19	7265	Steel Rivet, 0.25 x 0.375 inch ...	2
5	100424	Right Side Mast Stiffener	1	20	6732	Screw - HHC, 1/2 -13 x 3.25 inches, GR 5	
6	32473	Roller, 1.75 x 0.72 inch	4	21	11978	Nylon Flat Washer, 1/2 inch	
7	33843	Mast Stiffener Spacer, 4.56 x 0.75 inch	1	22	100309	Pin Assembly with Lanyard.....	1
8	6198	Nylock Nut, 1/2 -13		23	6587	Rubber Grip	2
9	13005	Screw - HHC, 1/2 -13 x 6 inches, GR 8	1	24	33385	Push-on Washer, 0.75 inch	2
10	100425	Left Side Mast Stiffener	1	25	6564	Shim Washer, 0.75 x 1.125 x 0.093 inch	4
11	6095	Flat Washer, 1/2 inch (before serial number SLC05-30640)		26	57788	Wheel, 6 x 2 inches	2
—	109560	Nylon Washer, .51x .75 x .125 inch (after serial number SLC05-30639)		—	37202	Inner Axle Bushing	
12	32475	Roller Bolt, 1/2 -13 x 1.84 inches	2	27	33540	Loading Wheel Assembly with Decals (before serial number SLA04-25259) (USA, Canadian and Australian models after serial number SLA04-25258) (includes items 24 - 27)	1
13	32474	Roller Guard.....	2	—	107156	Loading Wheel Assembly with Decals (before serial number SLA04-25259) (Asia, S. America and European models after serial number SLA04-25258) (includes items 24 - 27)	
14	80162	Winch Mount with Decals (before serial number SLA04-25259) (USA, Canadian and Australian models after serial number SLA04-25258)	1	28	35834	Winch Spacer, One-speed (SLA-5 and SLA-10).....	1
—	107155	Winch Mount with Decal (before serial number SLA04-25259) (Asia, S. America and European models after serial number SLA04-25258)		29	Ref.	Winch Assembly (refer to Figures 8-E or 8-F)	
				30	49991	Winch Spacer, Two-speed (SLA-5 and SLA-10).....	1

Figure 8-B

REV B

Mast Components, View 2

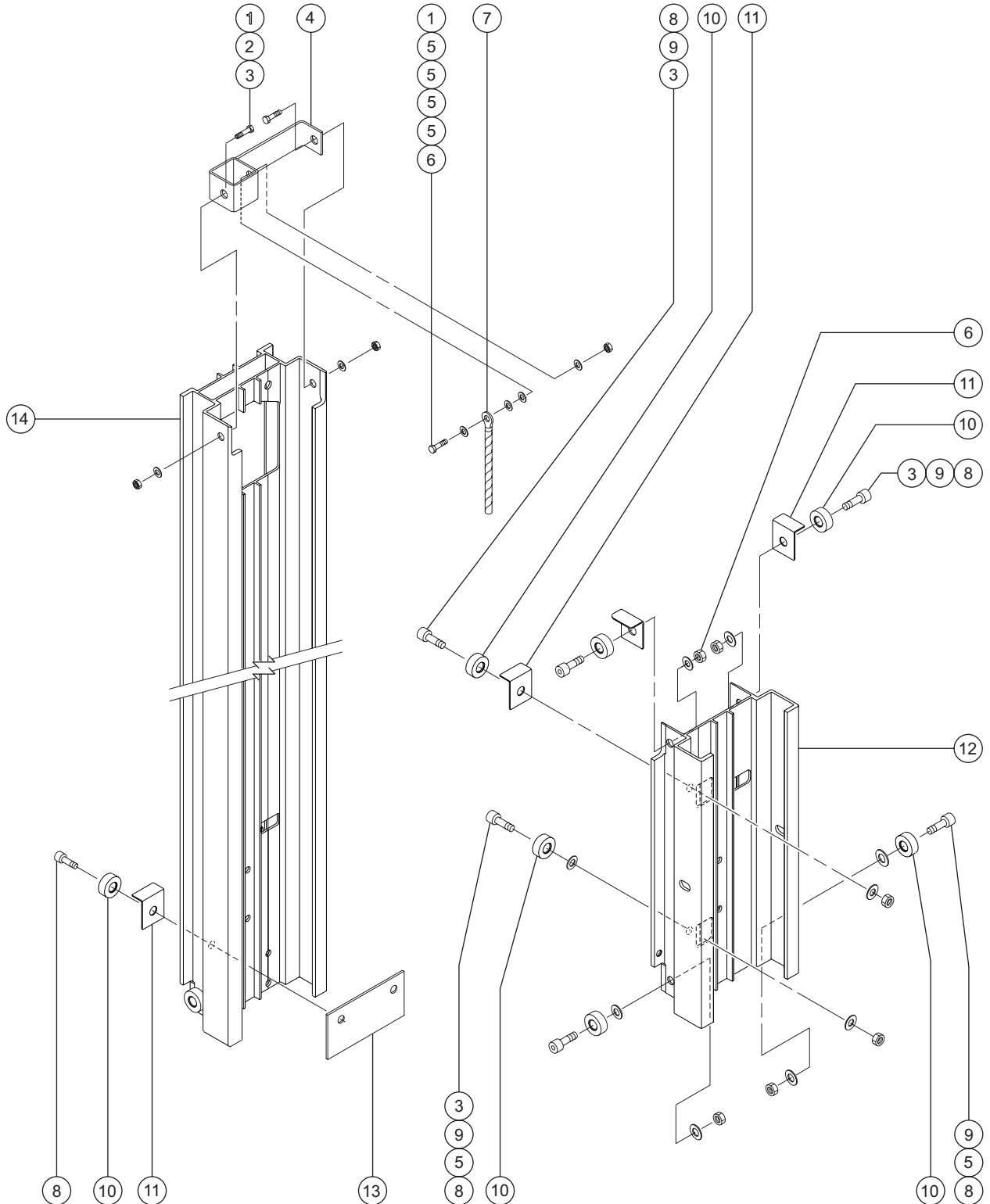

REV B

FIGURE 8-B

Item	Part No.	Description	Qty.
1	10597	Screw - HHC, 1/2 -13 x 1.25 inches, GR 5	
2	6095	Flat Washer, 1/2 inch (before serial number SLC05-30640)	
—	109560	Nylon Washer, .51x .75 x .125 inch (after serial number SLC05-30639)	
3	6198	Nylock Nut, 1/2 -13	
4	35081	Cable Anchor (before serial number SLA03-20409)	1
—	80986	Cable Anchor (after serial number SLA03-20408)	
5	6052	Shim Washer, 0.5 x 0.875 x 0.063 inch	7
6	6086	Low Profile Nylock Nut, 1/2 -13	
7	Ref.	Cable Assembly (refer to Figure 8-D)	
8	32475	Roller Bolt, 1/2 -13 x 1.84 inches	8
9	13066	Hardened Flat Washer, 1/2 inch	
10	32473	Roller, 1.75 x 0.72 inch	8
11	32474	Roller Guard	5
12	Ref.	Carriage (refer to Figure 8-D)	
13	57016	Doubler Plate	1
14	Ref.	Number 1 Column (refer to Figure 8-D)	

Figure 8-C

REV C

Mast Components, View 3

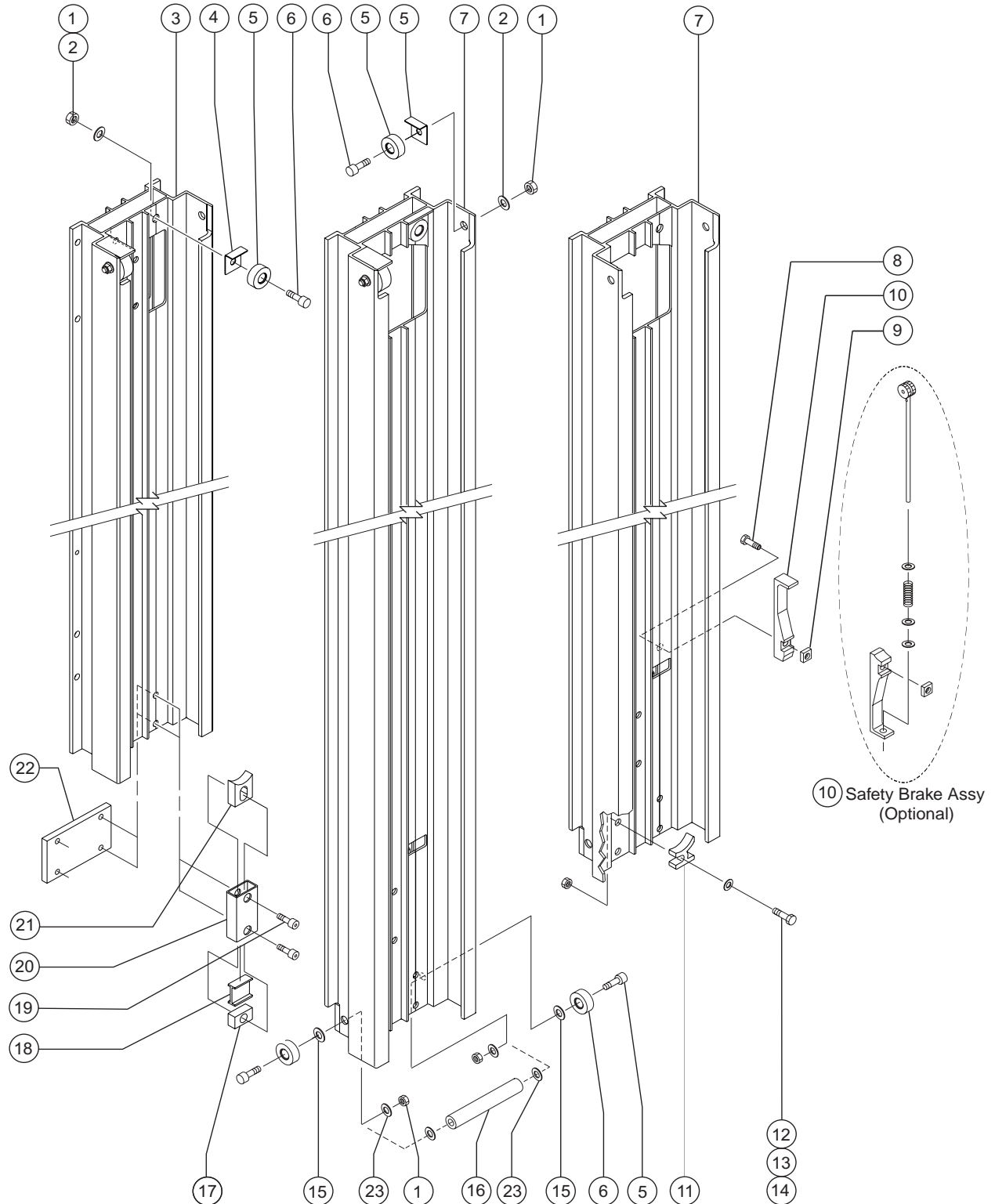

REV C

FIGURE 8-C

Item	Part No.	Description	Qty.	Item	Part No.	Description	Qty.
1	6198	Nylock Nut, 1/2 -13 (SLA-5, SLA-10, SLA-15, SLA-20 and SLA-25 models)		7	Ref.	Number 2 Column (refer to Figure 8-D)	
2	6095	Flat Washer, 1/2 inch (0.562 x 1.375 x 0.109 inch) (SLA-5, SLA-10, SLA-15, SLA-20 and SLA-25 models) (before serial number SLC05-30640)		8	35463	Screw - FHS, 3/8 -16 x 1.5 inches (SLA-5, SLA-10, SLA-15, SLA-20 and SLA-25 models)	
—	109560	Nylon Washer, .51x .75 x .125 inch (SLA-5, SLA-10, SLA-15, SLA-20 and SLA-25 models) (after serial number SLC05-30639)		9	35408	Square Nut, 3/8 -16, Plated (SLA-5, SLA-10, SLA-15, SLA-20 and SLA-25 models)	
3	Ref.	Number 1 Column (refer to Figure 8-D)		10	35443	Up Stop (for models without safety brake) (SLA-5)	1
4	32474	Roller Guard (SLA-5)	3	—	35443	Up Stop (for models without safety brake) (SLA-10)	2
—	32474	Roller Guard (SLA-10)	7	—	35443	Up Stop (for models without safety brake) (SLA-15)	3
—	32474	Roller Guard (SLA-15)	12	—	35443	Up Stop (for models without safety brake) (SLA-20)	4
—	32474	Roller Guard (SLA-20)	17	—	35443	Up Stop (for models without safety brake) (SLA-25)	5
—	32474	Roller Guard (SLA-25)	22	10	35101	Safety Brake Assembly (if equipped) (SLA-15) (includes items 8 and 9)	2
5	32473	Roller, 1.75 x 0.72 inch (SLA-5)	3	—	35101	Safety Brake Assembly (if equipped) (SLA-20) (includes items 8 and 9)	3
—	32473	Roller, 1.75 x 0.72 inch (SLA-10)	9	—	35101	Safety Brake Assembly (if equipped) (SLA-25) (includes items 8 and 9)	3
—	32473	Roller, 1.75 x 0.72 inch (SLA-15)	14	11	32522	Down Stop	1
—	32473	Roller, 1.75 x 0.72 inch (SLA-20)	19	12	6019	Screw - HHC, 3/8 -16 x 1.25 inches, GR 5	
—	32473	Roller, 1.75 x 0.72 inch (SLA-25)	24	13	12013	Shim Washer, 0.375 x 0.625 x 0.063 inch	1
6	32475	Roller Bolt, 1/2 -13 x 1.84 inches (SLA-5)	3	14	4828	Nylock Nut, 3/8 -16	
—	32475	Roller Bolt, 1/2 -13 x 1.84 inches (SLA-10)	9	15	6052	Shim Washer, 0.5 x 0.875 x 0.063 inch (SLA-5, SLA-10, SLA-15, SLA-20 and SLA-25 models)	
—	32475	Roller Bolt, 1/2 -13 x 1.84 inches (SLA-15)	14	This list continues on the next page.			
—	32475	Roller Bolt, 1/2 -13 x 1.84 inches (SLA-20)	19				
—	32475	Roller Bolt, 1/2 -13 x 1.84 inches (SLA-25)	24				

FIGURE 8-C

REV C

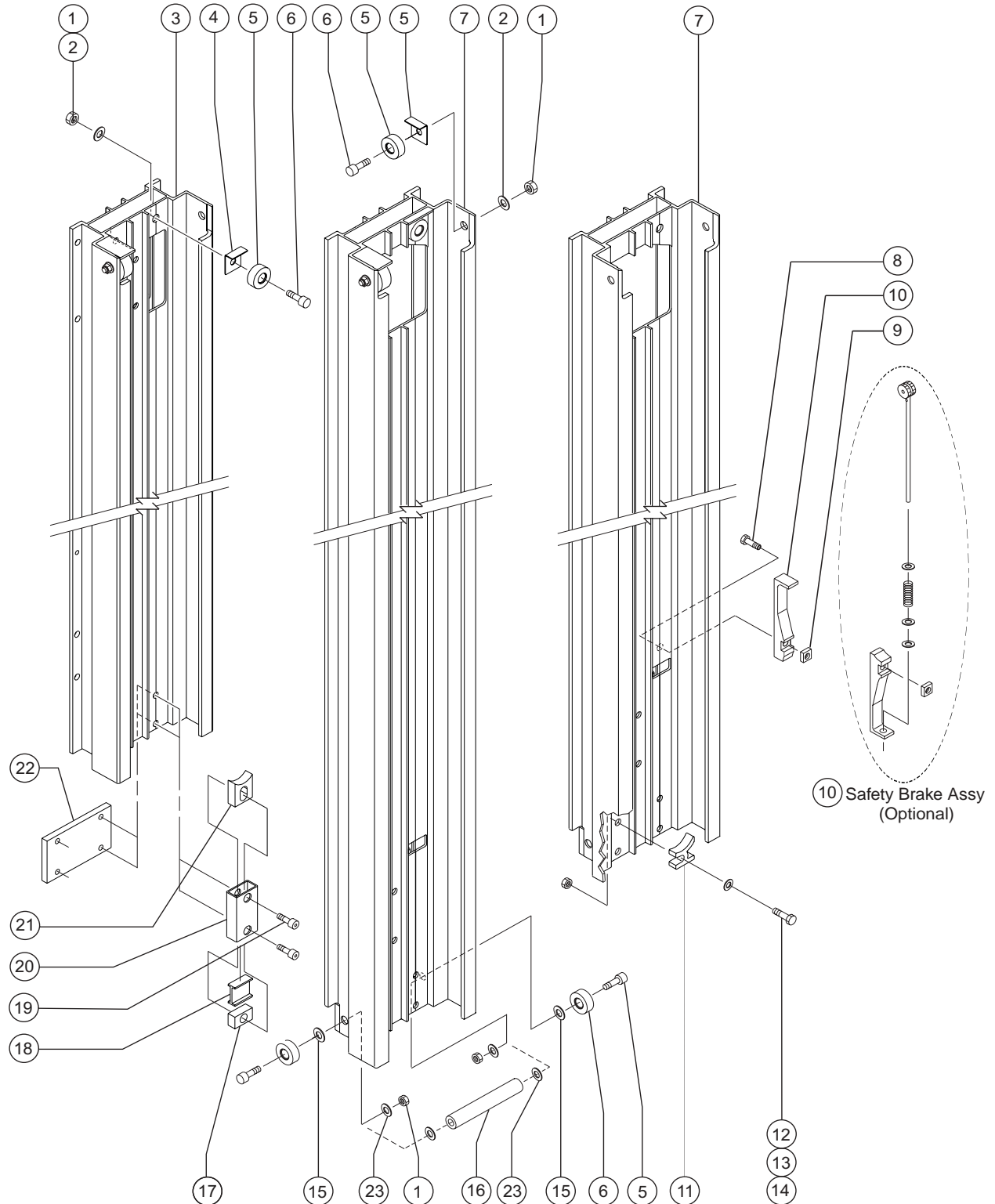

REV C

FIGURE 8-C

Item	Part No.	Description	Qty.
16	33811	Coupler Bar (SLA-20 and SLA-25)	1
17	57019	Down Stop Block (SLA-10)	1
—	57019	Down Stop Block (SLA-15)	4
—	57019	Down Stop Block (SLA-20)	6
—	57019	Down Stop Block (SLA-25)	8
18	57022	Down Stop Rubber Bumper (SLA-10)	1
—	57022	Down Stop Rubber Bumper (SLA-15)	4
—	57022	Down Stop Rubber Bumper (SLA-20)	6
—	57022	Down Stop Rubber Bumper (SLA-25)	8
19	57023	Shoulder Bolt, ³ / ₈ -16 x 0.75 inch, GR 5 (SLA-10, SLA-15, SLA-20 and SLA-25 models)	
20	57021	Down Stop Tube (SLA-10)	1
—	57021	Down Stop Tube (SLA-15)	4
—	57021	Down Stop Tube (SLA-20)	6
—	57021	Down Stop Tube (SLA-25)	8
21	57018	Down Stop Plunger Block (SLA-10, SLA-15, SLA-20 and SLA-25)	1
22	57024P	Down Stop Plate (SLA-10, SLA-15, SLA-20 and SLA-25)	1
23	13066	Hardened Flat Washer, 1/2 inch	

Figure 8-D

Columns, Pulleys and Cables

REV C

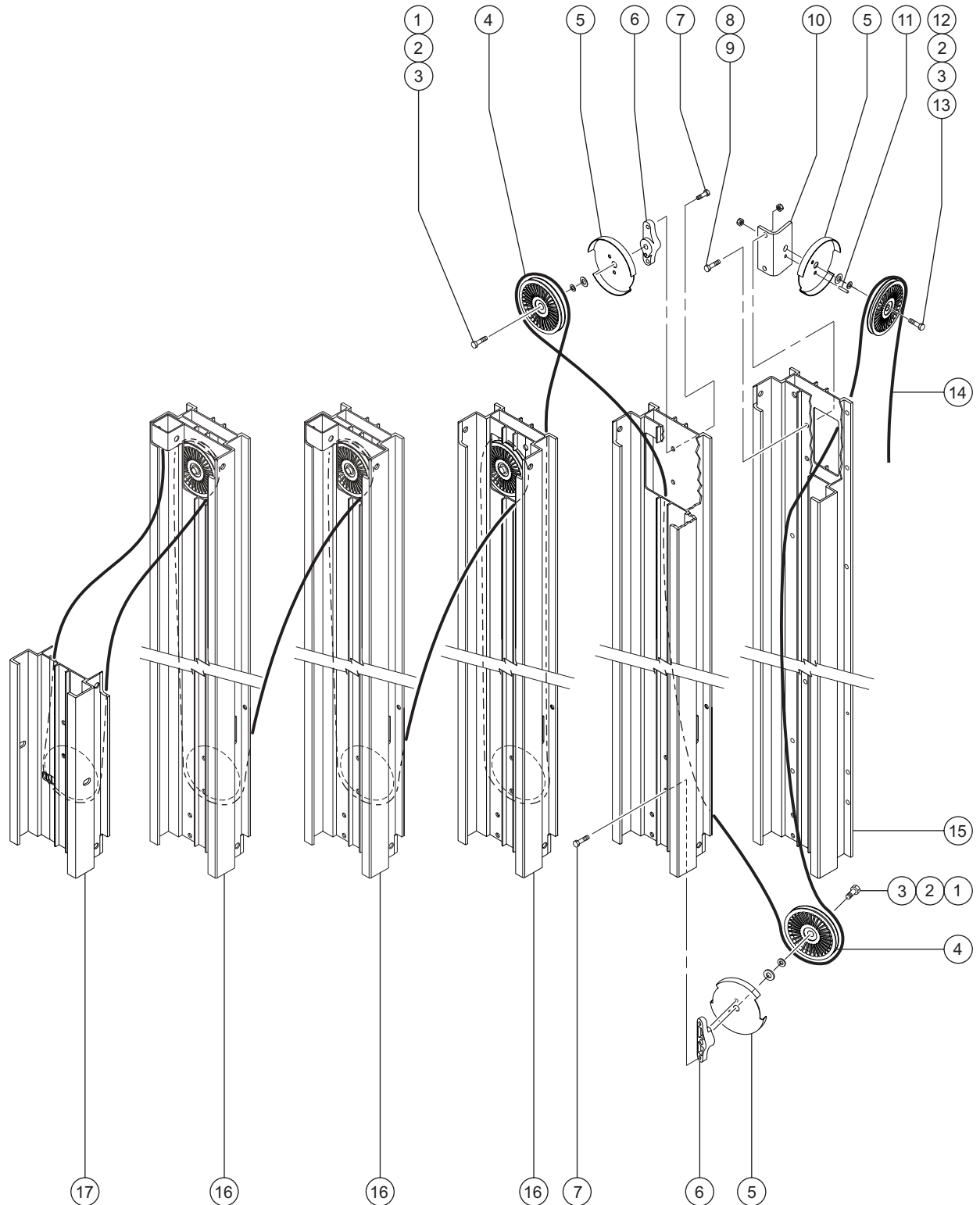

REV C

FIGURE 8-D

Item	Part No.	Description	Qty.	Item	Part No.	Description	Qty.
1	10597	Screw - HHC, 1/2 -13 x 1.25 inches, GR 5 (SLA-5)	1	4	49999	Pulley with Bearing, 4.65 x 4.05 inches (SLA-5)	2
—	10597	Screw - HHC, 1/2 -13 x 1.25 inches, GR 5 (SLA-10)	3	—	49999	Pulley with Bearing, 4.65 x 4.05 inches (SLA-10)	4
—	10597	Screw - HHC, 1/2 -13 x 1.25 inches, GR 5 (SLA-15)	5	—	49999	Pulley with Bearing, 4.65 x 4.05 inches (SLA-15)	6
—	10597	Screw - HHC, 1/2 -13 x 1.25 inches, GR 5 (SLA-20)	7	—	49999	Pulley with Bearing, 4.65 x 4.05 inches (SLA-20)	8
—	10597	Screw - HHC, 1/2 -13 x 1.25 inches, GR 5 (SLA-25)	9	—	49999	Pulley with Bearing, 4.65 x 4.05 inches (SLA-25)	10
2	37038	Shim Washer, 0.51 x 0.8 x 0.125 inch (SLA-5)	2	5	80680	Pulley Guard (SLA-5)	2
—	37038	Shim Washer, 0.51 x 0.8 x 0.125 inch (SLA-10)	4	—	80680	Pulley Guard (SLA-10)	4
—	37038	Shim Washer, 0.51 x 0.8 x 0.125 inch (SLA-15)	6	—	80680	Pulley Guard (SLA-15)	6
—	37038	Shim Washer, 0.51 x 0.8 x 0.125 inch (SLA-20)	8	—	80680	Pulley Guard (SLA-20)	8
—	37038	Shim Washer, 0.51 x 0.8 x 0.125 inch (SLA-25)	10	—	80680	Pulley Guard (SLA-25)	10
3	6052	Shim Washer, 0.5 x 0.875 x 0.063 inch (SLA-5)	2	6	32470	Pulley Mount (SLA-5)	1
—	6052	Shim Washer, 0.5 x 0.875 x 0.063 inch (SLA-10)	4	—	32470	Pulley Mount (SLA-10)	3
—	6052	Shim Washer, 0.5 x 0.875 x 0.063 inch (SLA-15)	6	—	32470	Pulley Mount (SLA-15)	5
—	6052	Shim Washer, 0.5 x 0.875 x 0.063 inch (SLA-20)	8	—	32470	Pulley Mount (SLA-20)	7
—	6052	Shim Washer, 0.5 x 0.875 x 0.063 inch (SLA-25)	10	—	32470	Pulley Mount (SLA-25)	9
				7	8255	Screw - HHC, 3/8 -16 x 0.75 inch, GR 5 (SLA-5)	2
				—	8255	Screw - HHC, 3/8 -16 x 0.75 inch, GR 5 (SLA-10)	6
				—	8255	Screw - HHC, 3/8 -16 x 0.75 inch, GR 5 (SLA-15)	10

This list continues on the next page.

FIGURE 8-D

REV C

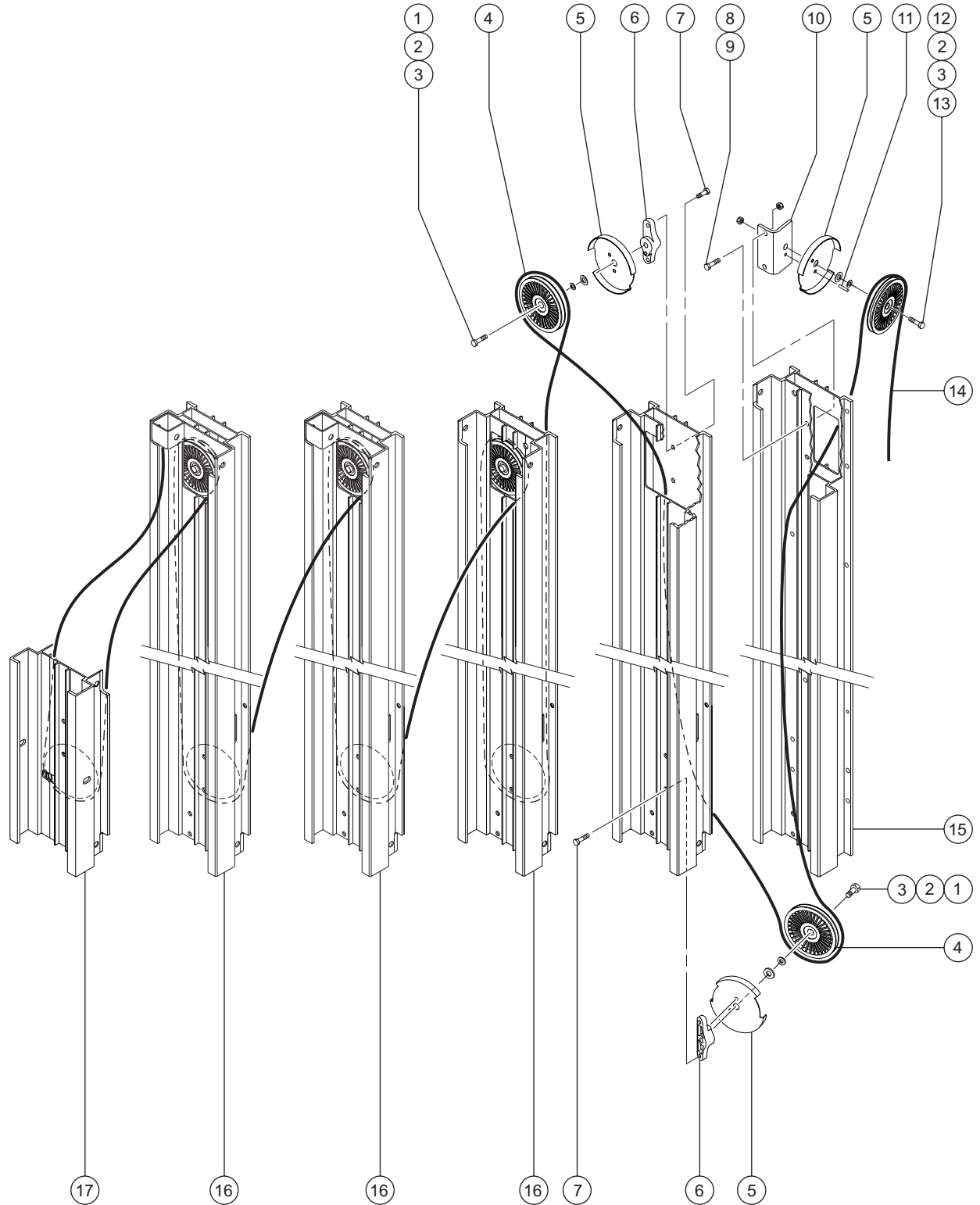

REV C

FIGURE 8-D

Item	Part No.	Description	Qty.	Item	Part No.	Description	Qty.
7	8255	Screw - HHC, 3/8 -16 x 0.75 inch, GR 5 (SLA-20).....	14	16	57033-S	Number 2 Column (SLA-10) (after serial number 5599-3360).....	1
—	8255	Screw - HHC, 3/8 -16 x 0.75 inch, GR 5 (SLA-25).....	20	—	57033-S	Number 2 Column (SLA-15) (after serial number 5599-3361).....	2
8	6019	Screw - HHC, 3/8 -16 x 1.25 inches, GR 5 (all models)		—	57033-S	Number 2 Column (SLA-20) (after serial number 5599-3404).....	3
9	4828	Nylock Nut, 3/8 -16		—	57033-S	Number 2 Column (SLA-25) (after serial number 5599-3827).....	4
10	32471	Pulley Guard Bracket (all models)	1	17	57034	Carriage (SLA-5) (after serial number 5599-3745)	1
11	32483	Roll Pin, 0.25 x 0.5 inch (all models)	1	—	57034	Carriage (SLA-10) (after serial number 5599-3360)	
12	8177	Screw - HHC, 1/2 -13 x 1.5 inches, GR 5 (all models)		—	57034	Carriage (SLA-15) (after serial number 5599-3361)	
13	6198	Nylock Nut, 1/2 -13 (all models)		—	57035	Carriage (SLA-20) (after serial number 5599-3404)	
14	6443	Cable Assembly (SLA-5)	1	—	57035	Carriage (SLA-25) (after serial number 5599-3827)	
—	6444	Cable Assembly (SLA-10)					
—	32903	Cable Assembly (SLA-15)					
—	32904	Cable Assembly (SLA-20)					
—	32905	Cable Assembly (SLA-25)					
15	57032-S	Number 1 Column (SLA-5) (after serial number 5599-3745).....	1				
—	57032-S	Number 1 Column (SLA-10) (after serial number 5599-3360)					
—	57032-S	Number 1 Column (SLA-15) (after serial number 5599-3361)					
—	57032-S	Number 1 Column (SLA-20) (after serial number 5599-3404)					
—	57032-S	Number 1 Column (SLA-25) (after serial number 5599-3827)					

Figure 8-E

Winch Components, One-speed

REV C

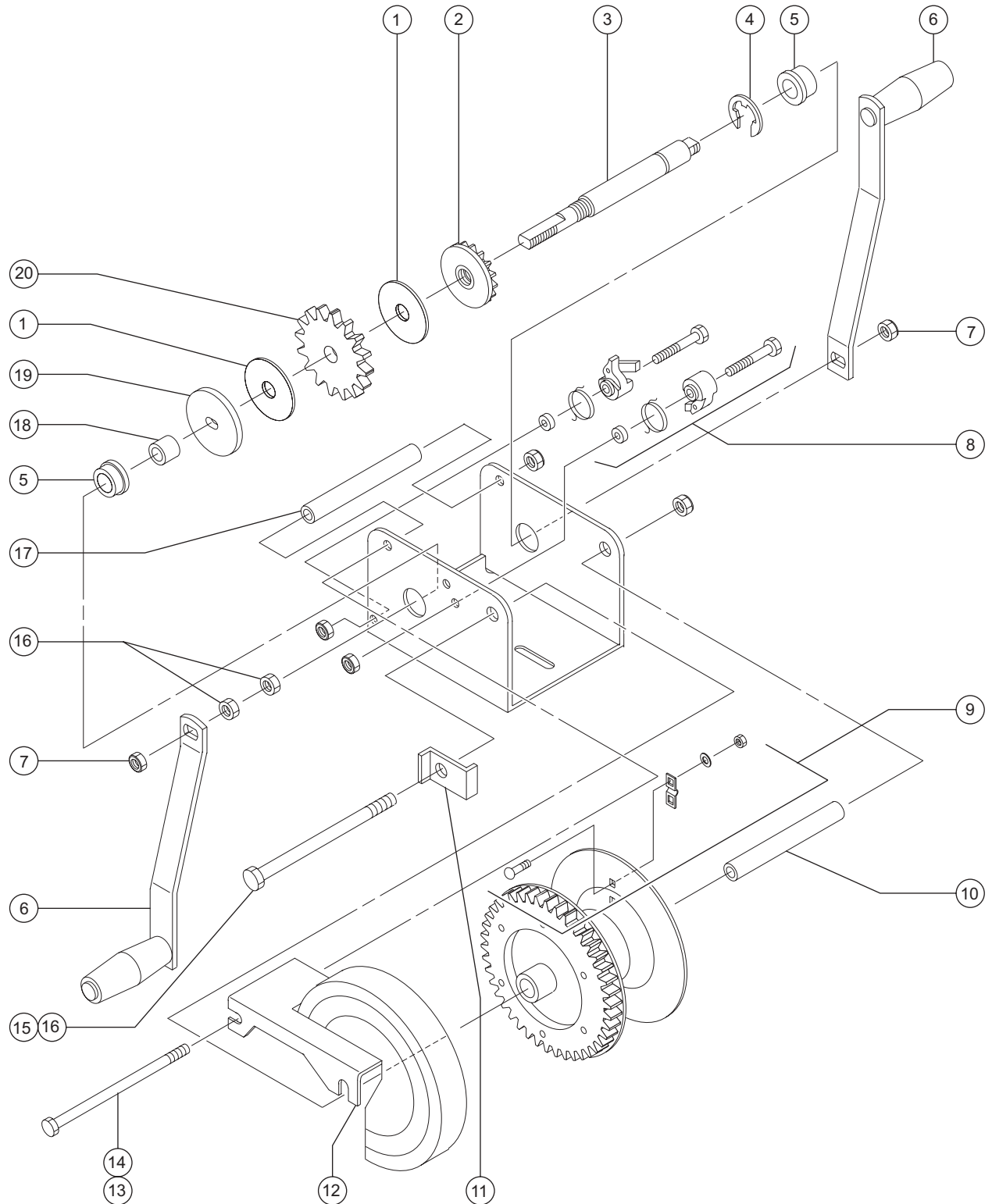

REV C

FIGURE 8-E

Item	Part No.	Description	Qty.	Item	Part No.	Description	Qty.
—	32945	Winch Assembly with Decals (before serial number SLA04-25259) (USA, Canadian and Australian models after serial number SLA04-25258)		16	6034	Hex Jam Nut, 1/2 -13	
—	107157	Winch Assembly with Decals (before serial number SLA04-25259) (Asia, S. America and European models after serial number SLA04-25258)		17	7584	Frame Spacer 1	
				18	32890	Pinion Shaft Spacer 1	
				19	7591	Pinion Plate 1	
				20	6777	Ratchet Gear 1	
1	7571	Disc Brake 2					
2	7590	Pinion Gear 1					
3	32891	Pinion Shaft 1					
4	6200	Retaining Ring, 0.75 inch 1					
5	6199	Pinion Shaft Bushing 2					
6	33143	Winch Handle, 6 inches (SLA-5) 2					
—	33144	Winch Handle, 8 inches (SLA-10, SLA-15, SLA-20 and SLA-25)					
7	6086	Low Profile Nylock Nut, 1/2 -13					
8	40458	Ratchet Pawl Kit 1					
9	6190	Cable Keeper Kit 1					
—	80159	Carriage Bolt, 10-24 x 0.63 inch					
—	80160	Cable Keeper					
—	80161	Internal Star Washer, 5/8 inch					
—	25625	Hex Nut, 10-24					
10	6184	Drum Spacer 1					
11	31946	Drum Lock Bolt 1					
12	6770	Winch Gear Cover 1					
13	7256	Screw - HHC, 5/16 -18 x 6 inches, GR 2					
14	6782	Lock Nut, 5/16 -18					
15	6185	Drum Bolt 1					

Figure 8-F

REV C

Winch Components, Two-speed

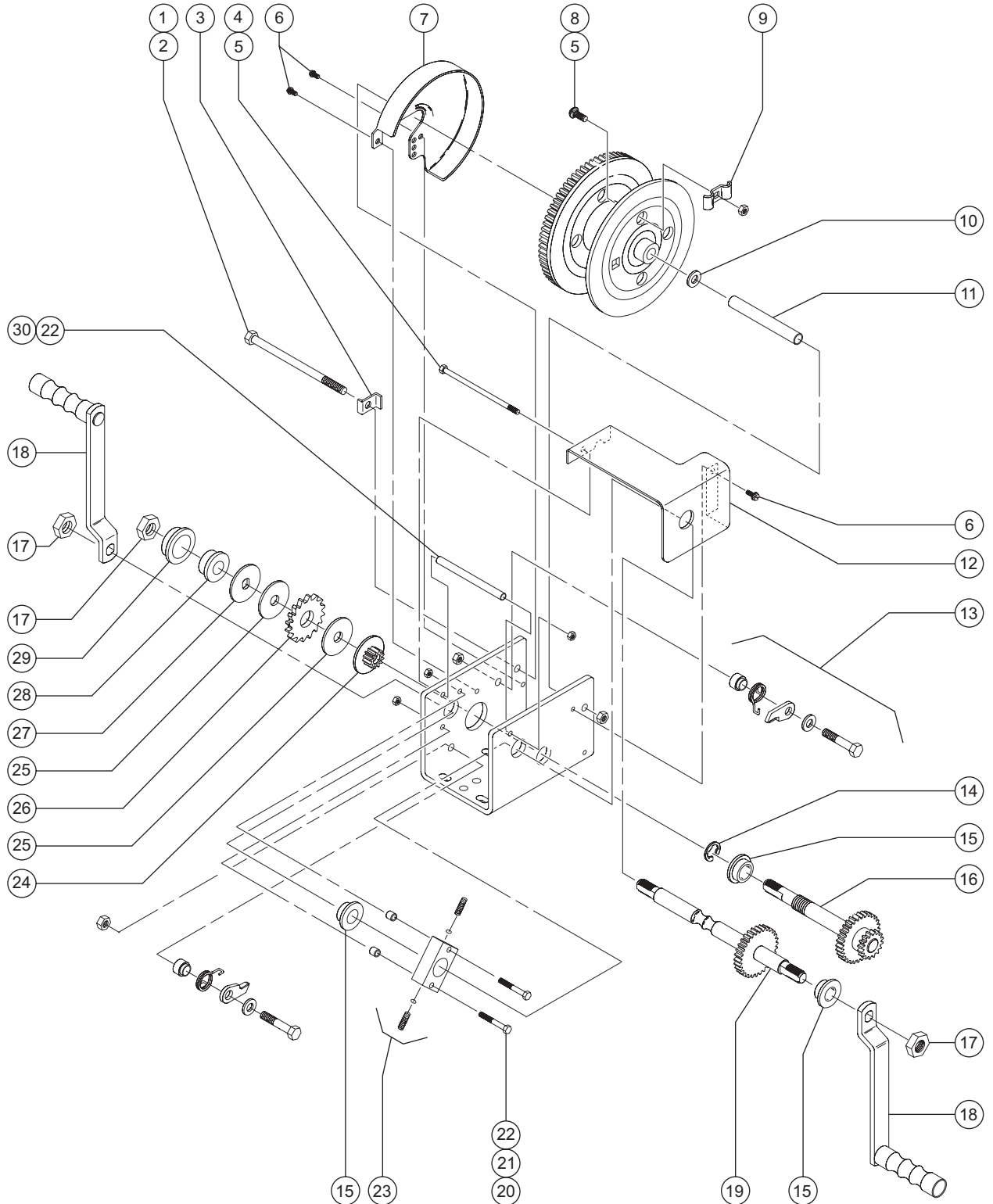

REV C

FIGURE 8-F

Item	Part No.	Description	Qty.	Item	Part No.	Description	Qty.
—	32946	Winch Assembly with Decals (before serial number SLA04-25259) (USA, Canadian and Australian models after serial number SLA04-25258)		14	40116	Retaining Ring, 0.75 inch.....	1
—	107158	Winch Assembly with Decals (before serial number SLA04-25259) (Asia, S. America and European models after serial number SLA04-25258)		15	40126	Sintered Iron Bearing, 0.75 inch	
—	40130	Cable Keeper Kit (includes items 5, 8 and 9)		16	80155	Pinion Shaft Assembly	1
1	78037	Screw - HHC, 3/8 -16 x 5.5 inches		17	38028	Low Profile Nylock Nut, 5/8 -11	
2	4828	Nylock Nut, 3/8 -16		18	40125	Handle, 8 inches	2
3	80145	Reel Lock Bolt	1	19	72264	Input Shaft Assembly	1
4	80146	Screw - HHC, 1/4 -20 x 5.25 inches		20	6145	Screw - HHC, 1/4 -20 x 1.5 inches, GR 5	
5	6091	Nylock Nut, 1/4 -20		21	40115	Brake Spring Spacer	2
6	80147	Screw - FHC, Threaded, 1/2 inch		22	6889	Low Profile Nylock Nut, 1/4 -20	
7	80148	Reel Cover	1	23	40127	Detent Block Assembly	1
8	80149	Carriage bolt, 1/4 -20 x 0.5 inch		—	40509	Detent Spring	2
9	37065	Cable Keeper	1	—	40510	Detent Ball	2
10	80150	Flat Washer, 1/2 inch		—	80156	Detent Block	1
11	40113	Reel Spacer	1	24	80157	Pinion Gear	1
12	80151	Gear Cover	1	25	37061	Disc Brake	2
13	40117	Ratchet Pawl Kit.....	1	26	37062	Ratchet Gear	1
—	8516	Screw - HHC, 3/8 -16 x 1.5 inches, GR 5		27	40122	Pinion Plate	1
—	5397	Flat Washer, 5/16 inch		28	40123	Brake Spacer	1
—	80154	Ratchet Pawl		29	37064	Pinion Shaft Bushing	1
—	80153	Ratchet Spring		30	40128	Base Spacer	1
—	80152	Ratchet Spacer					
—	4828	Nylock Nut, 3/8 -16					

Section Nine

Accessories

Figure 9-A

REV B

Forks

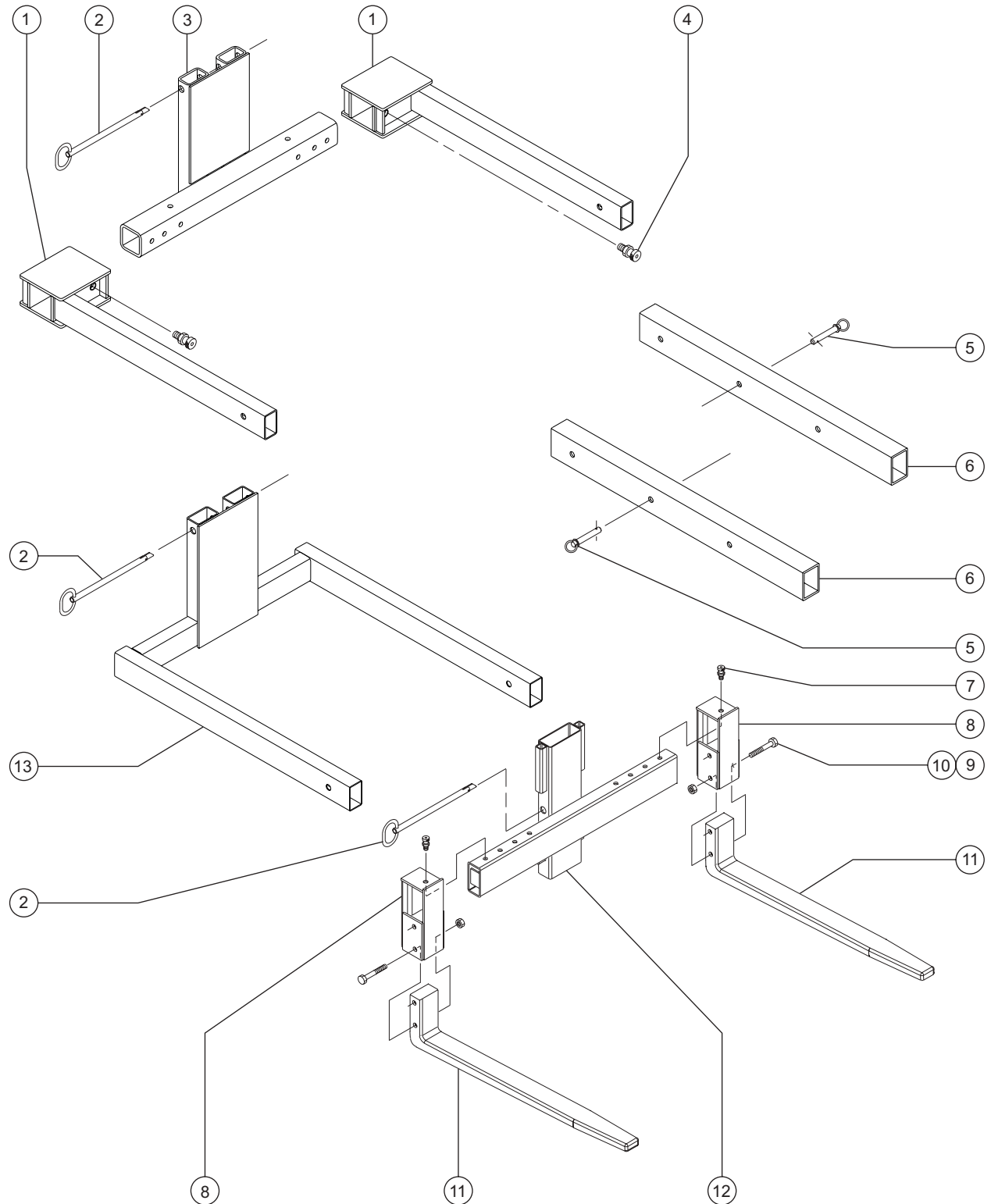

REV B

FIGURE 9-A

Item	Part No.	Description	Qty.	Item	Part No.	Description	Qty.
—	32564-S	Adjustable Fork Assembly with Decals (before serial number SLA04-25259) (USA, Canadian and Australian models after serial number SLA04-25258) (includes Items 1- 4)		12	32907	Flat Forks Carrier Assembly with Decals (before serial number SLA04-25259) (USA, Canadian and Australian models after serial number SLA04-25258)	1
—	107161	Adjustable Fork Assembly with Decals (Asia, S. America and European models after serial number SLA04-25258) (includes Items 1- 4)		—	107163	Flat Forks Carrier Assembly (Asia, S. America and European models after serial number SLA04-25258)	
1	32548-S	Adjustable Fork	2	13	32906	Standard fork with Decals (before serial number SLA04-25259) (USA, Canadian and Australian models after serial number SLA04-25258)	1
2	48301	Toggle Pin, 0.5 x 8.13 inches	3	—	107164	Standard fork with Decals (Asia, S. America and European models after serial number SLA04-25258)	
3	32908	Adjustable Carrier Assembly with Decals (before serial number SLA04-25259) (USA, Canadian and Australian models after serial number SLA04-25258)	1				
—	107162	Adjustable Carrier Assembly with Decals (Asia, S. America and European models after serial number SLA04-25258)					
4	33674	Snap Pin, 0.375 x 0.25 inch	2				
5	80679	Ball Retaining Pin, 0.5 x 2.7 inches	2				
6	33366-S	Fork Extension	2				
7	32375	Snap Pin, 0.63 x 2.29 inches	2				
8	32541-S	Flat Fork Socket	2				
9	8220	Screw - HHC, 1/2 -13 x 4 inches, GR 5					
10	6198	Nylock Nut, 1/2 -13					
11	32539	Flat Fork Casting	2				

Figure 9-B

REV B

Pipe Cradle, Load Platform and Boom Arm

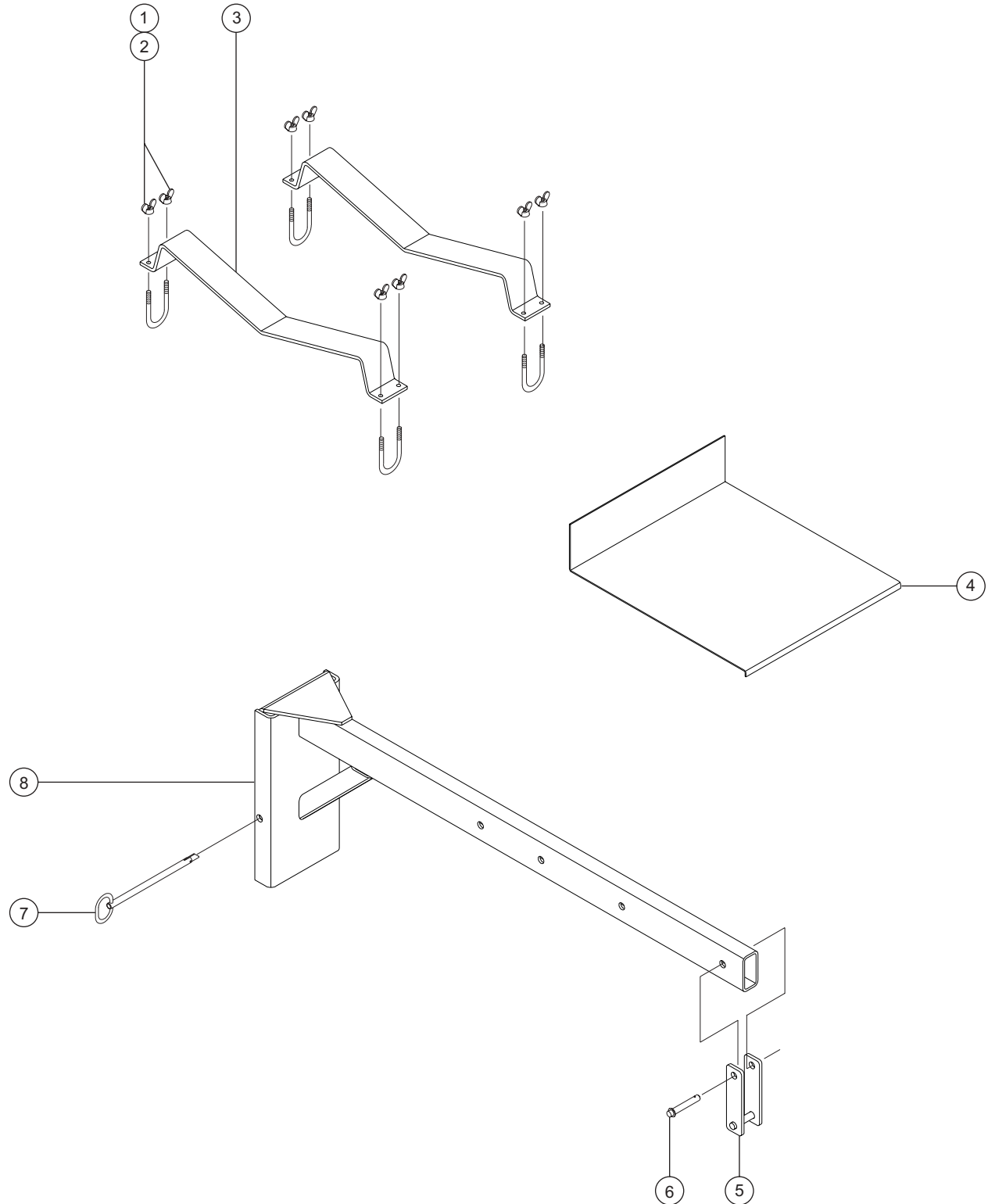

REV B

FIGURE 9-B

Item	Part No.	Description	Qty.
1	8170	Wing Nut, 1/4 -20	
2	33045	U-bolt, 1/4 -20 x 1.5 x 3.75 x 1.25 inches	4
3	80597	Pipe Cradle	2
4	32937	Load Platform Assembly with Decals (before serial number SLA04-25259) (USA, Canadian and Australian models after serial number SLA04-25258)	1
—	107165	Load Platform Assembly with Decals (Asia, S. America and European models after serial number SLA04-25258)	
5	32579-S	Clevis Boom	1
6	80679	Ball Retaining Pin, 0.5 x 2.7 inches	1
7	48301	Toggle Pin, 0.5 x 8.13 inches	1
8	32567-S	Boom Arm Assembly with Decals (before serial number SLA04-25259) (USA, Canadian and Australian models after serial number SLA04-25258) (includes items 5 - 7)	1
—	107166	Boom Arm Assembly with Decals (Asia, S. America and European models after serial number SLA04-25258) (includes items 5 - 7)	

Figure 9-C

Rear Wheels

REV B

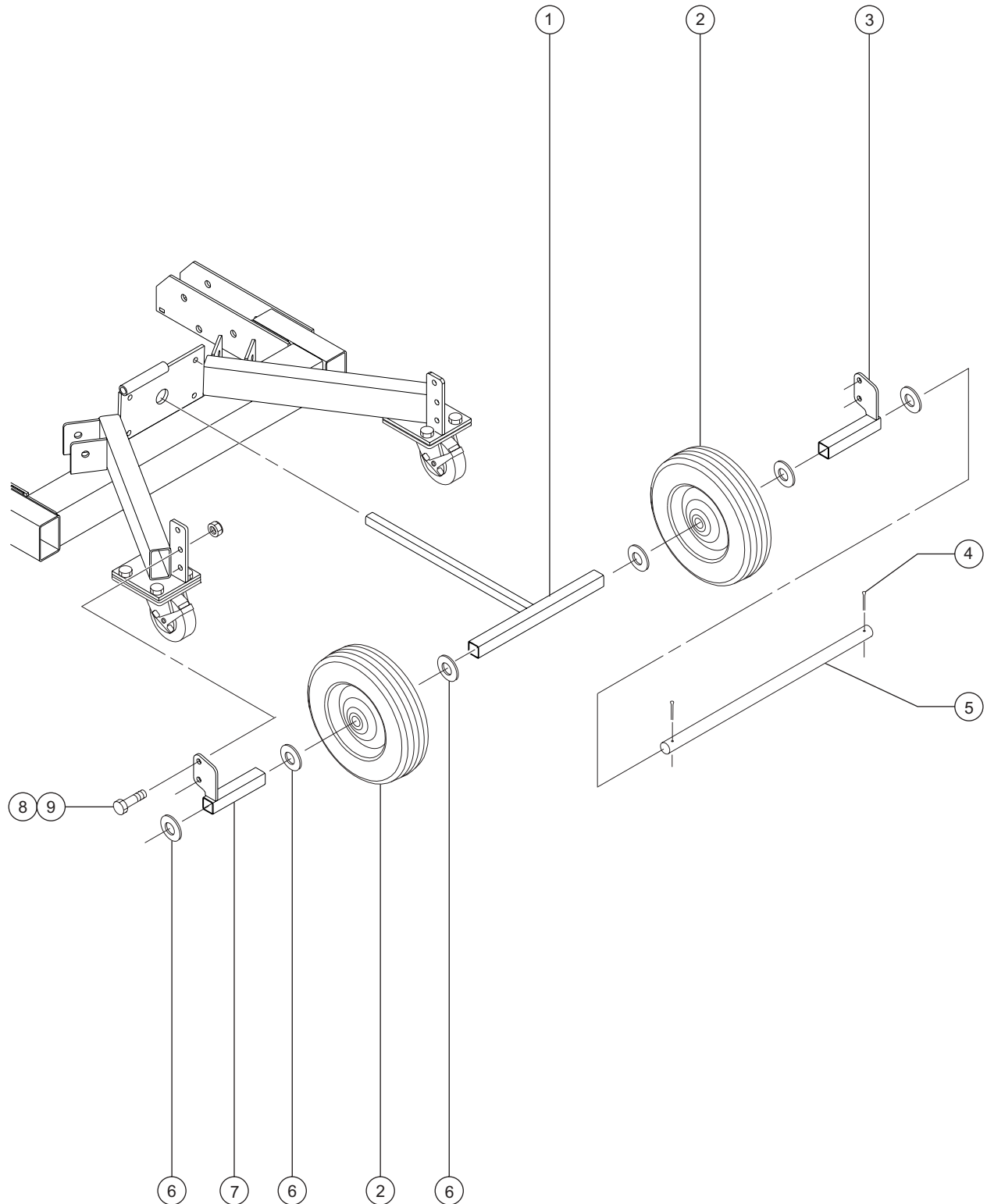

REV B

FIGURE 9-C

Item	Part No.	Description	Qty.
—	35848-S	Rear Wheel Accessory, Complete	
1	33831-S	Wheel Spacer	1
2	35064	Rear Wheel, 10 x 2.75 inches	2
3	33830-S	Rear Spacer Mount, Right Side	1
4	6094	Cotter Pin, 0.125 x 1 inch	2
5	57237	Transport Wheels Axle Rod	1
6	6564	Shim Washer, 0.75 x 1.125 x 0.093 inch	6
7	33829-S	Rear Spacer Mount, Left Side	1
8	6019	Screw - HHC, 3/8 -16 x 1.25 inches, GR 5	
9	4828	Nylock Nut, 3/8 -16	

Genie Scandinavia
Phone +46 31 3409612
Fax +46 31 3409613

Genie France
Phone +33 (0)2 37 26 09 99
Fax +33 (0)2 37 26 09 98

Genie Iberica
Phone +34 93 579 5042
Fax +34 93 579 5059

Genie Germany
Phone +49 (0)4202 88520
Fax +49 (0)4202 8852-20

Genie U.K.
Phone +44 (0)1476 584333
Fax +44 (0)1476 584334

Genie Mexico City
Phone +52 55 5666 5242
Fax +52 55 5666 3241

Genie North America
Phone 425.881.1800
Toll Free USA and Canada
800.536.1800
Fax 425.883.3475

Genie Australia Pty Ltd.
Phone +61 7 3375 1660
Fax +61 7 3375 1002

Genie China
Phone +86 21 53852570
Fax +86 21 53852569

Genie Malaysia
Phone +65 98 480 775
Fax +65 67 533 544

Genie Japan
Phone +81 3 3453 6082
Fax +81 3 3453 6083

Genie Korea
Phone +82 25 587 267
Fax +82 25 583 910

Genie Brasil
Phone +55 11 41 665 755
Fax +55 11 41 665 754

Genie Holland
Phone +31 10 220 7911
Fax +31 10 220 6642

Distributed By:

Parts and Service Manual Superlift Advantage *(after serial number SLA04-25258)*

Part No. 80170