

V. PARTS LIST SECTION

A. Ordering Information

1. List model number and serial number of machine.
2. List the part number and description of part (not item number).
3. Whenever alternate parts are shown due to product improvement, inspect the part you have and provide additional description as necessary.
4. Specify mode of shipping desired, for example, parcel post, truck, airfreight, U.P.S., best way, etc.

B. Parts List

See assembly drawing.

C. Power Unit Service Information

Repair or replacement service is available from your nearest authorized service station. Refer to the service center listing for the nearest authorized motor/engine service center.

V. PARTS LIST SECTION

Power Plant (BBC547) Gasoline

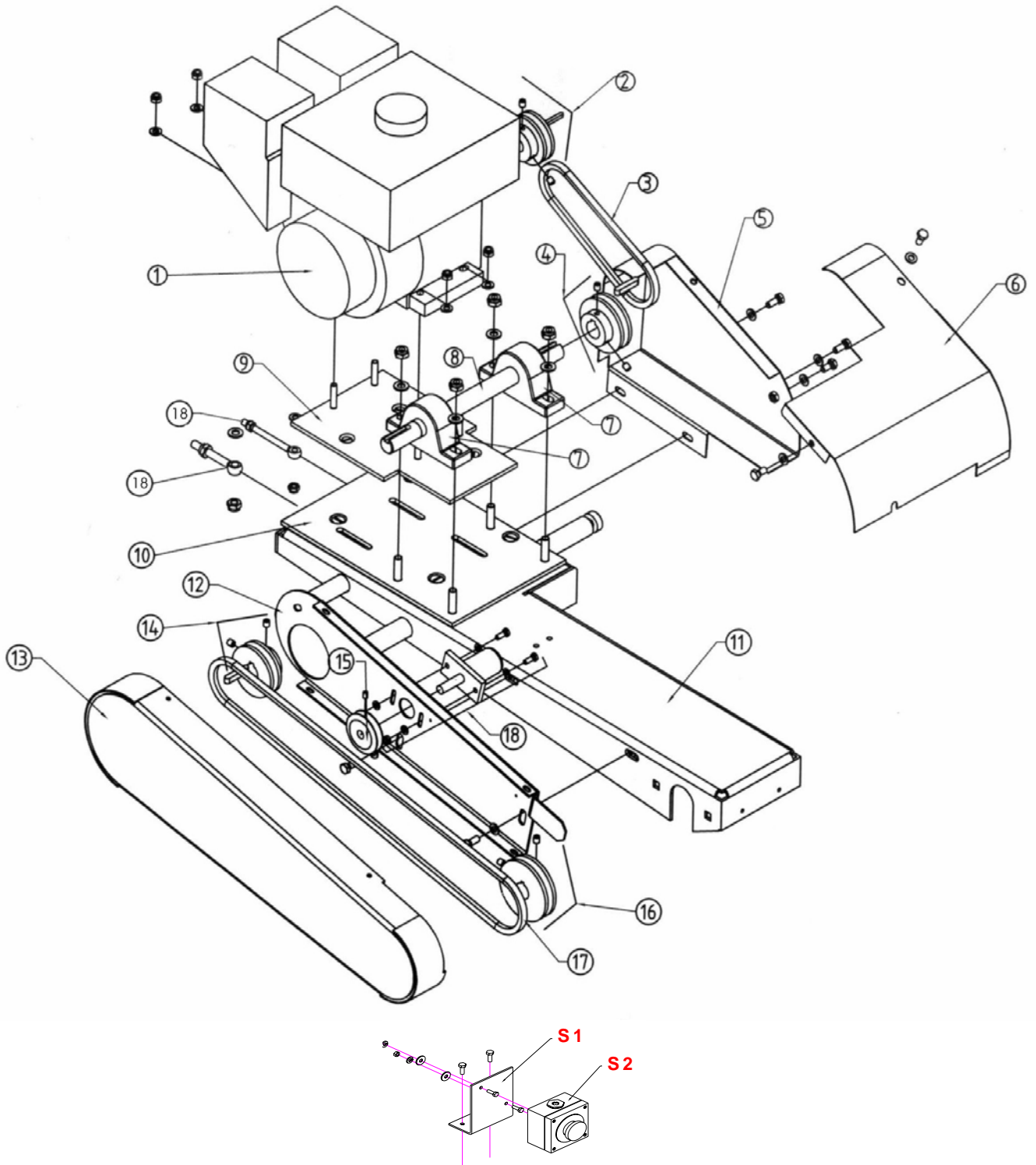

Power Plant (BBC547) Gasoline

Item No	Description	Part Number
1	Honda motor GX160	83715
2	Motor pulley	83716
3	Belt XPZ 562 LW	83717
4	Jackshaft pulley	83718
5	Right belt guard	83719
6	Guard for the jackshaft	83720
7	Bearing	70599
8	Jackshaft	83721
9	Motor fixation plate	83722
10	Jackshaft fixation plate	83723
11	Cutting head	83724
12	Support plate for belt guard	83725
13	Belt guard	83726
14	Jackshaft pulley	76102
15	Water pump pulley	75270
16	Blade shaft pulley	76098
17	Belt XPZ 1280 LW	70398
18	Eyebolt with Hardware (1)	76015
S1	Switch support	83746
S2	Emergency stop switch	83745

Power Plant (BBC157-207) Electric

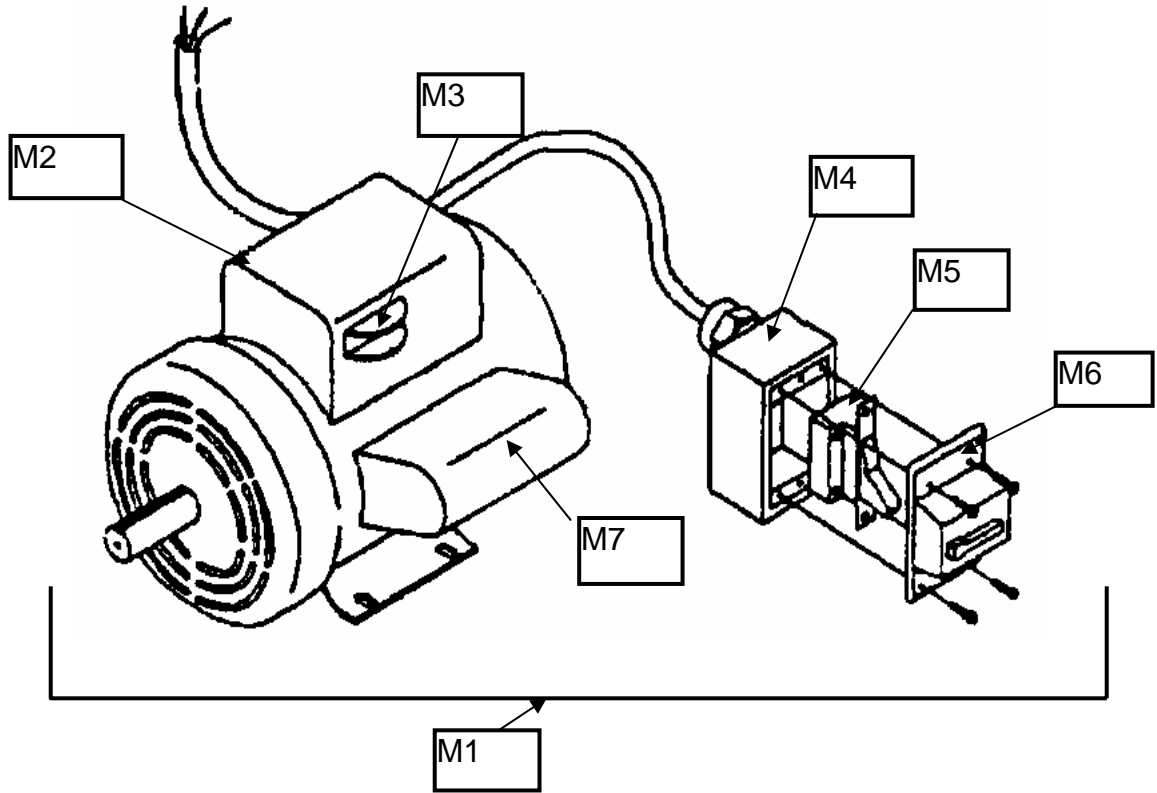

Item No	Description	Part Number
M1	Motor Assembly w/Switch 1-1/2HP 115/230v/60/1	232084
	Motor Assembly w/Switch 2 HP 115/230v/60/1	232085
M2	Capacitor Box Large (Terminal Box)	232085A
M3	Voltage Change Switch	231085
M4	Switch Box Rear	231087
M5	Switch On/Off	231089
M6	Switch Box Cover	231088
M7	Capacitor Box Small	231091
-NA-	Thermal Reset Button 1-1/2 HP Thermal Reset Button 2 HP <i>NOTE: The Thermal Reset Button Is Located On The Rear Of The Large Capacitor Housing</i>	
-NA-	Pulley 68MM OD 24MMB 1G Electric Models Only	83747
-NA-	Belt XPZ 1500 LW (1) Electric Models Only	72926

Frame (Common All BBC157-207-547)

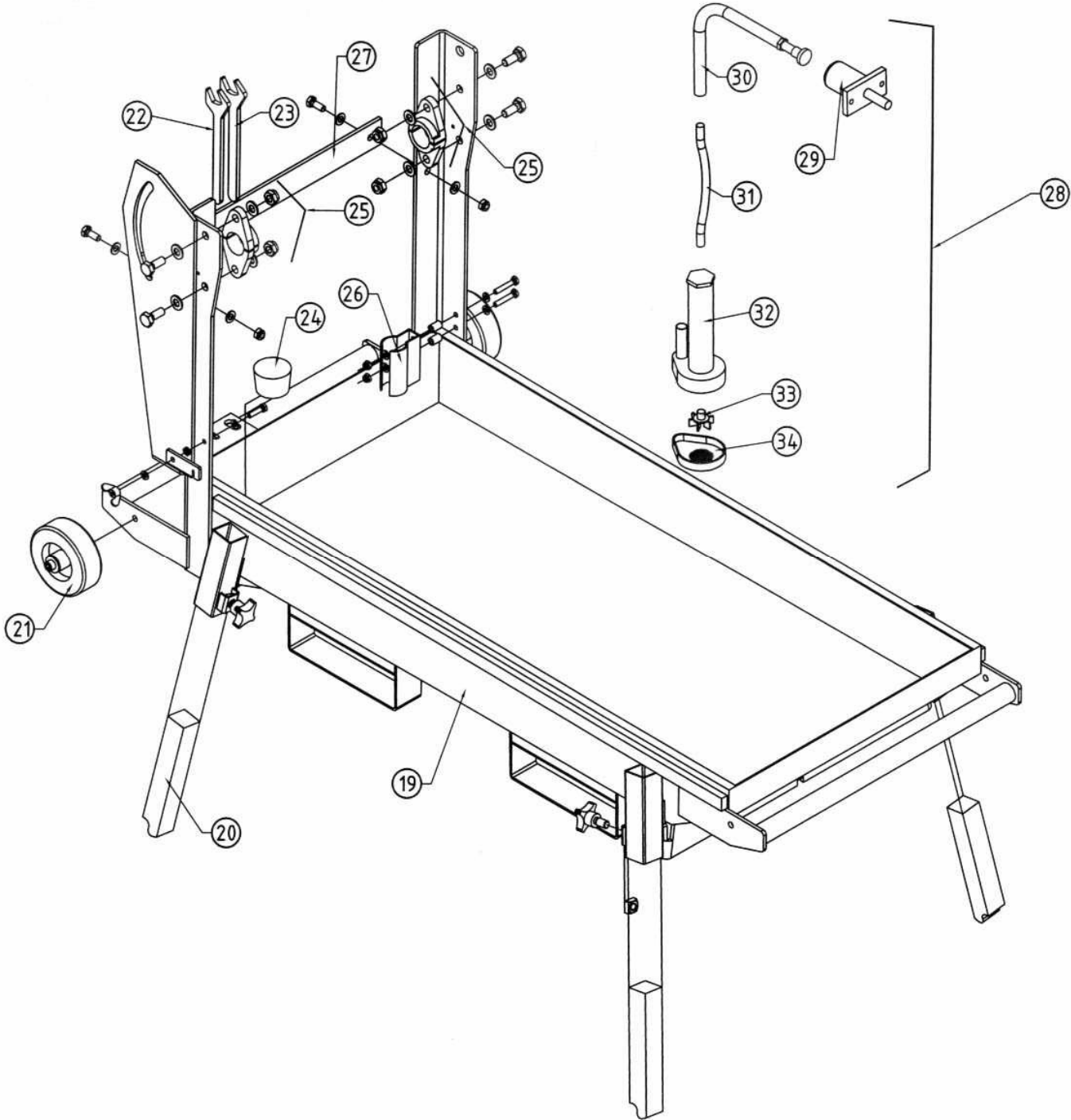

Frame (Common All BBC157-207-547))

Item No	Description	Part Number
18	Screws for water pump	75280
19	Frame	83727
20	Leg set of 4	75817
21	Wheel	82733
22	Wrench 19mm	70807
23	Wrench 22mm	72143
24	Drain plug	76095
25	Splited bearing	83728
26	Water pump fixation spring	76097
27	Support post	83729
28	Water pump complete.	72305
29	Drive end comp. For water pump	72297
30	Sheath for flexible shaft (Not Available, Now part of 72307)	-NA- Part of 72307
31	Flexible shaft complete for mech. water pump L=35.8 inches (910mm)	72307
32	Body of the pump	72284
33	Propeller water pump	72862
34	Plastic sieve for pump	72186
-NA-	Knob M10 X 20 1.5 for Legs (sold each)	72856

Cutting Head (Common All BBC157-207-547)

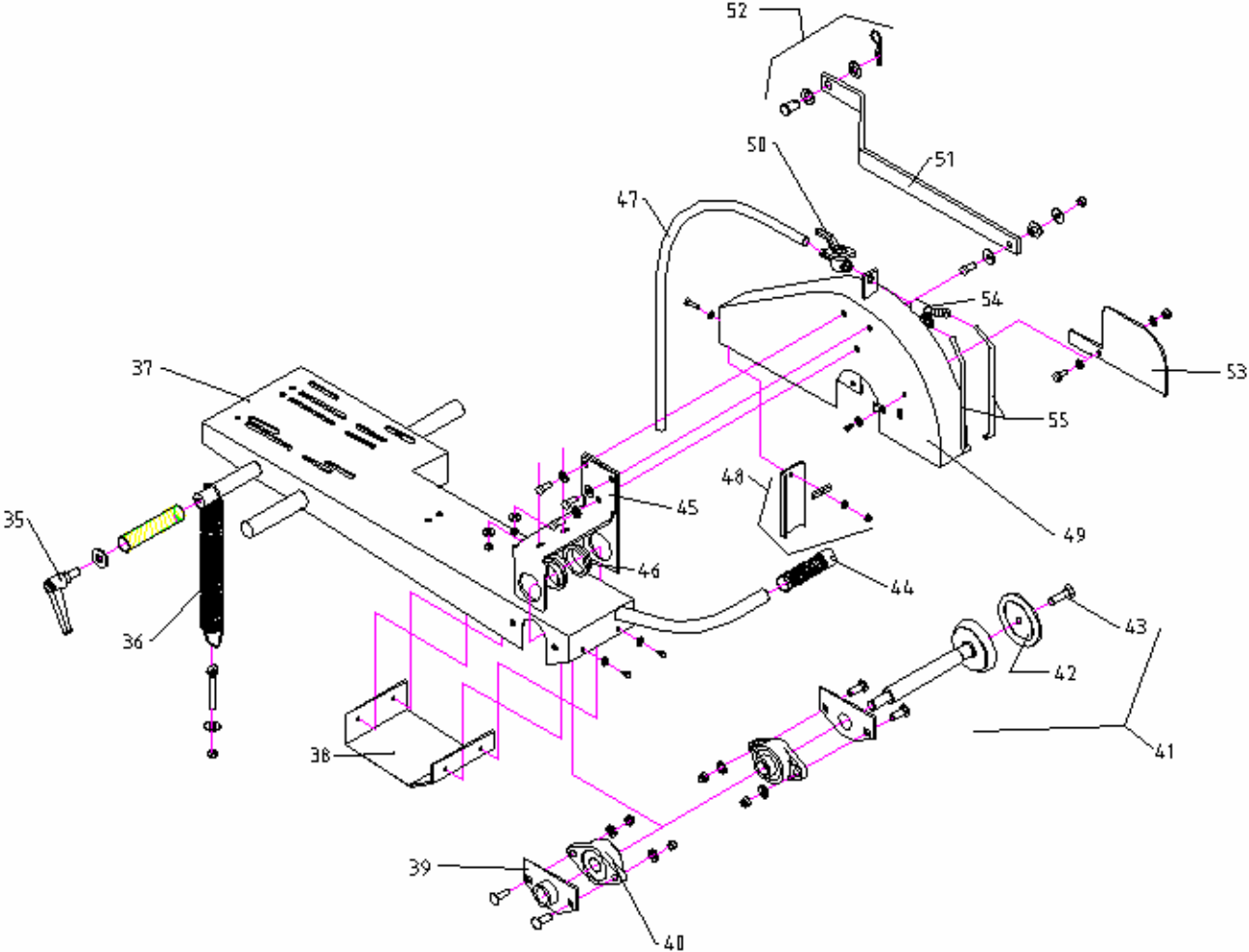

Cutting Head (Common All BBC157-207-547)

Item No	Description	Part Number
35	Locking Handle for cutting head (was 73098 replaced by 82738)	82738
36	Spring	72567
37	Cutting head	83724
38	Protection for Bearings and shaft	76111
39	Support for blade shaft bearing (set of 2)	76060
40	Bearing (set of 2)	73418
41	Blade shaft assembly	76035
42	Loose collar	73216
43	Screw for loose collar	73217
44	Handle grip	72097
45	Leveling support	76113
46	Bushings, bearing-Nylon (set of 2)	73220
47	Hose for water pump	72413
48	Splash guard	73221
49	Blade guard	76037
50	Water tap	72357
51	Stay-level arm	73266
52	Kit stay-level arm pin	76039
53	Blade shaft vent cover	76109
54	Y distributor	72286
55	Spray nozzle (set of 2)	80568

Cutting Table (Common All BBC157-207-547)

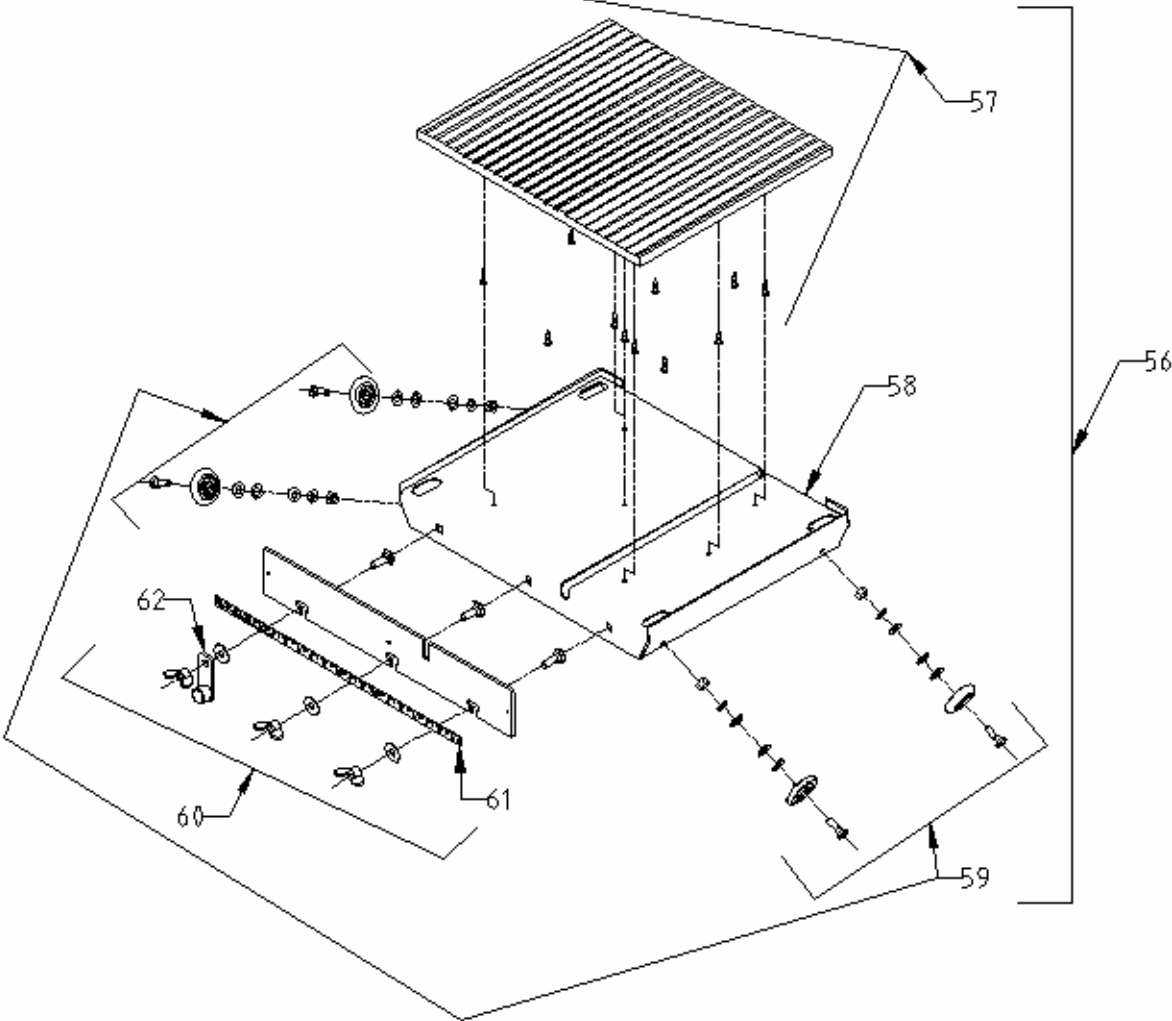

Cutting Table (Common All BBC157-207-547)

Item No	Description	Part Number
56	Conveyor Cart (aka Cutting Table) Complete With Wheels, Top, Back Stop, and Conveyor Cart Stop	83754
57	Top For Cutting Table (Wood & Rubber) w/Hardware	76742
	Screw 4x 12mm DIN 7976 (sold each, 11 required)	30373
58	Conveyor Cart Frame Only (No Wheels, Top, Backstop or Conveyor Cart Stop)	-NA- Part of 83754
59	Wheel Kit, Conveyor Cart (Set Of 4) w/Hardware	75333
	Carriage Bolt M10 x 30 DIN 603 (sold each, 3 required)	27282
	Washer 10.5 DIN 9021 (sold each, 3 required)	27508
	Wing Nut M10 DIN 315 (sold each, 3 required)	27040
60	Back Stop Plate	83752
61	Scale for Conveyor Cart w/rivets	83753
62	Stop Assembly for Conveyor Cart (Complete)	82856
	Rubber Stop	-NA- Part of 82856
	Nut M6 DIN 439	27003
	Washer M6 DIN 125	27539

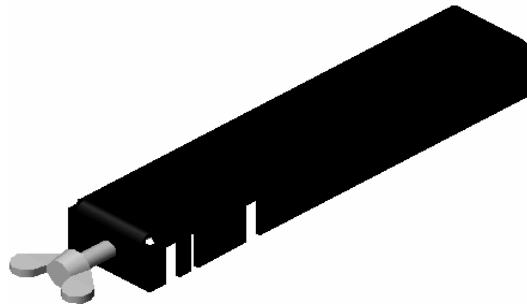

Item No	Description	Part Number
-NA-	Guide-A-Cut Assembly	83892